

## Sliding-gate operators

FA01442-EN



**BXV04AGS BXV06AGS BXV08AGS**  
**BXV10AGS BXV04RGS BXV06RGS**  
**BXV08RGS BXV10RGS BXV06AGM**  
**BXV10AGM BXV04ALS BXV06ALS**  
**BXV08ALS BXV10ALS**

INSTALLATION MANUAL

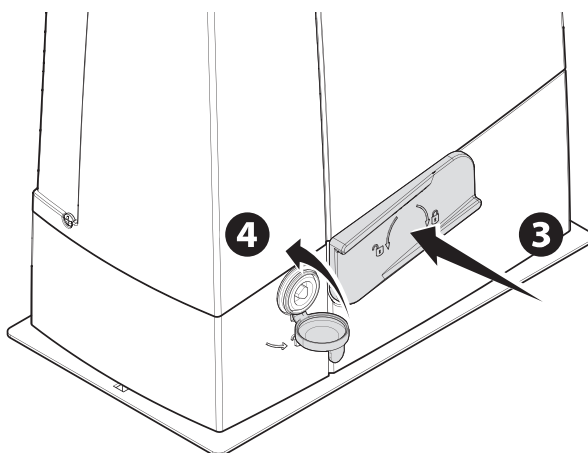
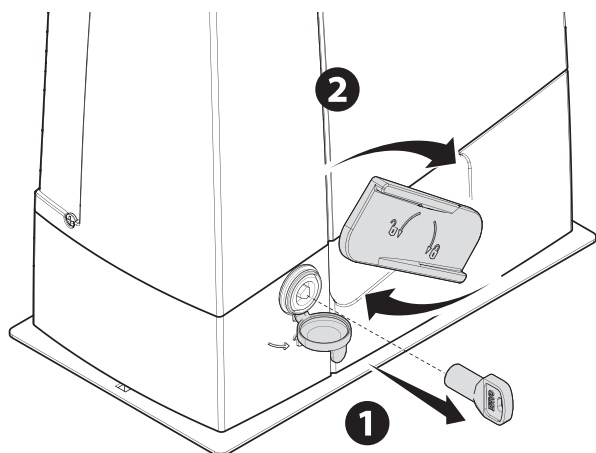
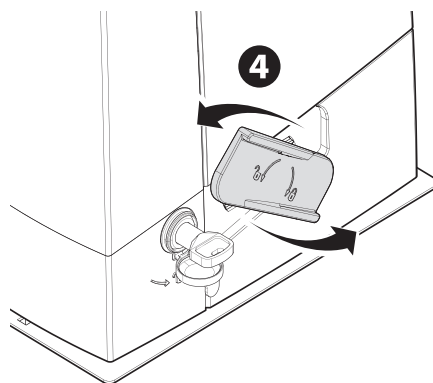
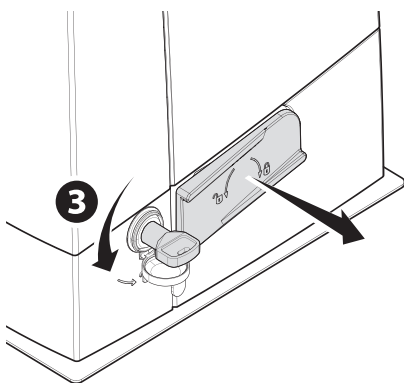
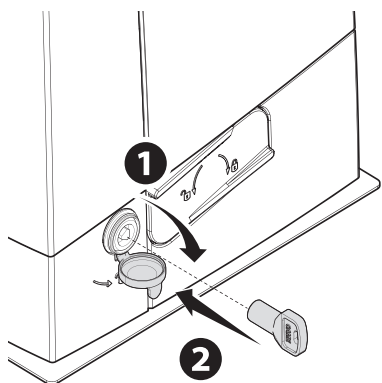

**△ Important safety instructions.****△ Please follow all of these instructions. Improper installation may cause serious bodily harm.****△ Before continuing, please also read the general precautions for users.**

Only use this product for its intended purpose. Any other use is hazardous.

- The manufacturer cannot be held liable for any damage caused by improper, unreasonable or erroneous use.
- This product is defined by the Machinery Directive (2006/42/EC) as partly completed machinery.
- Partly completed machinery means an assembly which is almost machinery but which cannot in itself perform a specific application.
- Partly completed machinery is only intended to be incorporated into or assembled with other machinery or other partly completed machinery or equipment thereby forming machinery to which the Machinery Directive (2006/42/EC) applies.
- The final installation must comply with the Machinery Directive (2006/42/EC) and the European reference standards in force.
- The manufacturer declines any liability for using non-original products, which would also void the warranty.
- All operations indicated in this manual must be carried out exclusively by skilled and qualified personnel and in full compliance with the regulations in force.
- The device must be installed, wired, connected and tested according to good professional practice, in compliance with the standards and laws in force.
- Make sure the mains power supply is disconnected during all installation procedures.
- Check that the temperature ranges given are suitable for the installation site.
- Do not install on slopes i.e. any surfaces that are not perfectly level.
- Do not install the operator on surfaces that could yield and bend. If necessary, add suitable reinforcements to the anchoring points.
- Make sure that no direct jets of water can wet the product at the installation site (sprinklers, water cleaners, etc.).
- Make sure you have set up a suitable dual-pole cut-off device along the power supply that is compliant with the installation rules. It should completely cut off the power supply according to category III surcharge conditions.
- Demarcate the entire site properly to prevent unauthorised personnel from entering, especially minors.
- In case of manual handling, have one person for every 20 kg that needs hoisting; for non-manual handling, use proper hoisting equipment in safe conditions.
- Use suitable protection to prevent any mechanical hazards due to persons loitering within the operating range of the operator.
- The electrical cables must pass through special pipes, ducts and cable glands in order to guarantee adequate protection against mechanical damage.
- The electrical cables must not touch any parts that may overheat during use (such as the motor and transformer).
- Before installation, check that the guided part is in good mechanical condition, and that it opens and closes correctly.
- The product cannot be used to automate any guided part that includes a pedestrian gate, unless it can only be enabled when the pedestrian gate is secured.
- Make sure that nobody can become trapped between the guided and fixed parts, when the guided part is set in motion.
- Use additional protection to prevent your fingers from being crushed between the pinion and rack.
- All fixed controls must be clearly visible after installation, in a position that allows the guided part to be directly visible, but far away from moving parts. In the case of a hold-to-run control, this must be installed at a minimum height of 1.5 m from the ground and must not be accessible to the public.
- If not already present, apply a permanent tag that describes how to use the manual release mechanism close to it.
- Make sure that the operator has been properly adjusted and that the safety and protection devices and the manual release are working properly.
- Before handing over to the final user, check that the system complies with the harmonised standards and the essential requirements of the Machinery Directive (2006/42/EC).
- Any residual risks must be indicated clearly with proper signage affixed in visible areas, and explained to end users.
- Put the machine's ID plate in a visible place when the installation is complete.
- If the power-supply cable is damaged, it must be immediately replaced by the manufacturer or by an authorised technical assistance centre, or in any case, by qualified staff, to prevent any risk.
- Keep this manual inside the technical folder along with the manuals of all the other devices used for your automation system.
- Make sure to hand over to the end user all the operating manuals of the products that make up the final machinery.

## Main points of danger for people

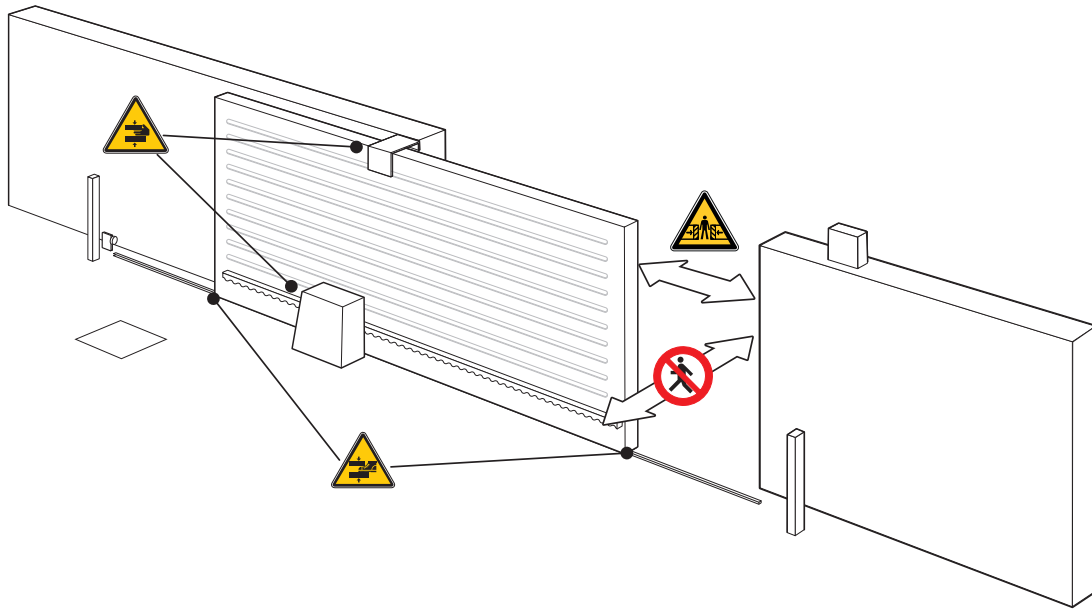

No transiting while the barrier is moving.



Risk of entrapment.



Risk of trapping hands.



Risk of trapping feet.

## DISMANTLING AND DISPOSAL

CAME S.p.A. employs an Environmental Management System at its premises. This system is certified and compliant with the UNI EN ISO 14001 standard to ensure that the environment is respected and safeguarded. Please continue safeguarding the environment. At CAME we consider it one of the fundamentals of our operating and market strategies. Simply follow these brief disposal guidelines:

### DISPOSING OF THE PACKAGING

The packaging materials (cardboard, plastic, etc.) can be disposed of easily as solid urban waste, separated for recycling.

Before dismantling and disposing of the product, please always check the local laws in force.

### DISPOSE OF THE PRODUCT RESPONSIBLY

#### DISPOSING OF THE PRODUCT

Our products are made of various materials. Most of these materials (aluminium, plastic, iron and electrical cables) are classified as solid urban waste. They can be separated for recycling and disposed of at authorised waste treatment plants.

Other components (electronic boards, transmitter batteries, etc.) may contain pollutants.





These must be removed and disposed of by an authorised waste disposal and recycling firm.

It is always advisable to check the specific laws that apply in your area.

### DISPOSE OF THE PRODUCT RESPONSIBLY

### Key

---

-  This symbol shows which parts to read carefully.
-  This symbol shows which parts describe safety issues.
-  This symbol shows what to tell users.
-  The measurements, unless otherwise stated, are in millimetres.

### Description

---

#### 801MS-0150

BXV04AGS - Operator with 24 V motor, featuring a control board with display, on-board radio decoding, movement and obstruction detecting device for gates weighing up to 400 kg that are up to 14 m long. RAL7024 grey cover.

#### 801MS-0180

BXV06AGS - Operator with 24 V motor, featuring a control board with display, on-board radio decoding, movement and obstruction detecting device for gates weighing up to 600 kg that are up to 18 m long. RAL7024 grey cover.

#### 801MS-0210

BXV08AGS - Operator with 24 V motor, featuring a control board with display, on-board radio decoding, movement and obstruction detecting device for gates weighing up to 800 kg that are up to 20 m long. RAL7024 grey cover.

#### 801MS-0230

BXV10AGS - Operator with 24 V motor, featuring a control board with display, on-board radio decoding, movement and obstruction detecting device for gates weighing up to 1000 kg that are up to 20 m long. RAL7024 grey cover.

#### 801MS-0260

BXV04RGS - Operator with 24 V motor, featuring a control board with display, on-board radio decoding, movement and obstacle detecting device for gates weighing up to 400 kg that are up to 14-m long. RAL7024-grey cover.

#### 801MS-0270

BXV06RGS - Operator with 24 V motor, featuring a control board with display, on-board radio decoding, movement and obstruction detecting device for gates weighing up to 600 kg that are up to 18 m long. RAL7024 grey cover.

#### 801MS-0280

BXV08RGS - Operator with 24 V motor, featuring a control board with display, on-board radio decoding, movement and obstacle detecting device for gates weighing up to 800 kg that are up to 20-m long. RAL7024-grey cover.

#### 801MS-0290

BXV10RGS - Operator with 24 V motor, featuring a control board with display, on-board radio decoding, movement and obstruction detecting device for gates weighing up to 1000 kg that are up to 20 m long. RAL7024 grey cover.

#### 801MS-0380

BXV06AGM - Operator with 24 V motor, featuring a control board with display, equipped with magnetic limit switches, on-board radio decoding, movement and obstacle detecting device for gates weighing up to 600 kg that are up to 18-m long. RAL7024-grey cover.

#### 801MS-0390

BXV10AGM - Operator with 24 V motor, featuring a control board with display, equipped with magnetic limit switches, on-board radio decoding, movement and obstacle detecting device for gates weighing up to 1,000 kg that are up to 20-m long. RAL7024-grey cover.

#### 801MS-0151

BXV04ALS - Operator with 24 V motor, featuring a control board with display, on-board radio decoding, movement and obstacle detecting device for gates weighing up to 400 kg that are up to 14-m long. RAL 7040 grey cover.

#### 801MS-0181

BXV06ALS - Operator with 24 V motor, featuring a control board with display, on-board radio decoding, movement and obstacle detecting device for gates weighing up to 600 kg that are up to 18-m long. RAL7040-grey cover.

#### 801MS-0211

BXV08ALS - Operator with 24 V motor, featuring a control board with display, on-board radio decoding, movement and obstruction detecting device for gates weighing up to 800 kg that are up to 20 m long. RAL7040 grey cover.

#### 801MS-0231

BXV10ALS - Operator with 24 V motor, featuring a control board with display, on-board radio decoding, movement and obstacle detecting device for gates weighing up to 1000 kg that are up to 20-m long. RAL7040-grey cover.

### Intended use

---

Sliding gate solution for residential buildings and apartment blocks

-  Any installation and/or use other than that specified in this manual is forbidden.

## Description of parts

### Operator

- ❶ Cover
- ❷ Board-holder support
- ❸ Gearmotor
- ❹ Anchoring plate
- ❺ Housing for two emergency batteries
- ❻ Transformer
- ❼ Mechanical limit switch
- ❽ Release cord hole
- ❾ Housing for the RGP1 module
- ❿ Housing for thermostat with cartridge
- ⓫ Board protection cover
- ⓬ Control board
- ⓭ Control board holder
- ⓮ Housing for the RLB card
- ⓯ Housing for UR042 module
- ⓰ Housing for SMA or RGSM001 sensor
- ⓱ Release lever
- ⓲ Lock
- ⓳ Mechanical limit-switch fins
- ⓴ Magnetic limit switch
- ⓵ Magnetic limit-switch fins

\*Only for BXV06AGM and BXV10AGM

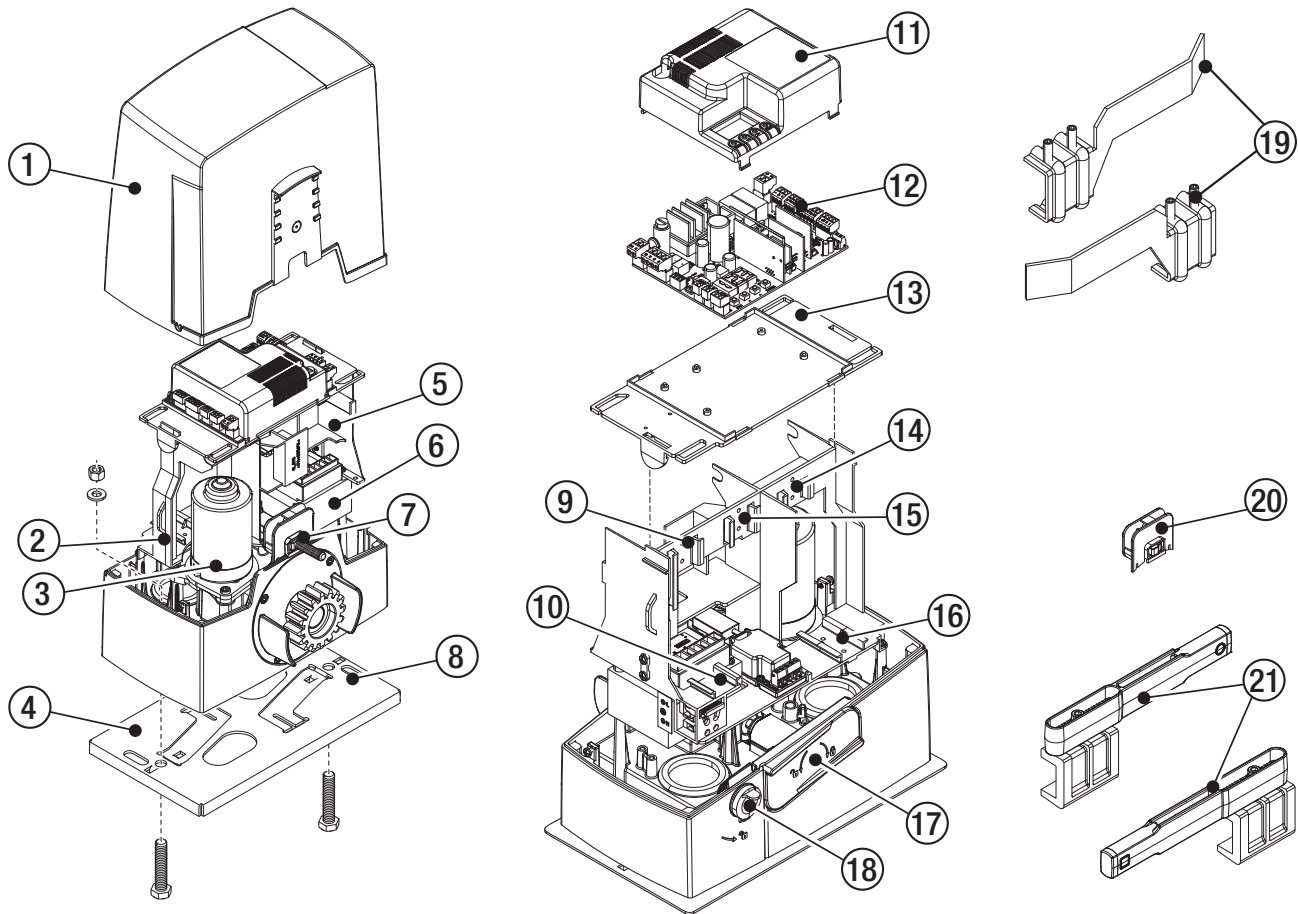

## Control board

The functions on the input and output contacts, the time settings and user management are set and viewed on the display.

All connections are protected by quick fuses.

For the system to work properly, before fitting any plug-in card, DISCONNECT THE MAIN POWER SUPPLY and remove any batteries.

Before working on the control panel, disconnect the mains power supply and remove the batteries, if any.

- ❶ Terminal board for connecting the gearmotor
- ❷ Terminal board for connecting the encoder
- ❸ Terminal board for connecting the limit switches
- ❹ Terminal board for connecting control and safety devices
- ❺ Terminal board for connecting the antenna
- ❻ Connector for plug-in radio frequency card (AF)
- ❼ Memory Roll card connector
- ❽ Connector for the R700 or R800 decoding card
- ❾ RSE card connector
- ❿ Connector for the RI0CN8WS module
- ⓫ Display
- ⓬ Programming buttons
- ⓭ Terminal board for connecting the paired function or the CRP
- ⓮ Terminal board for connecting the keypad selector
- ⓯ Terminal board for connecting the transponder selector switch
- ⓰ Connector for the GSM module
- ⓱ Terminal board for connecting the RGP1 module
- ⓲ Terminal board for connecting the signalling devices
- ⓳ Accessories fuse
- ⓴ Terminal board for power supply to the control board
- ⓵ Line fuse
- ⓶ Power supply terminal board

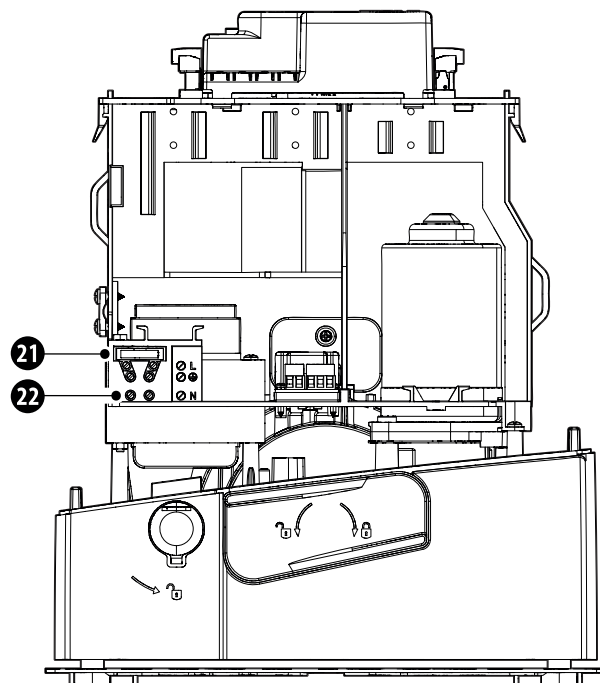
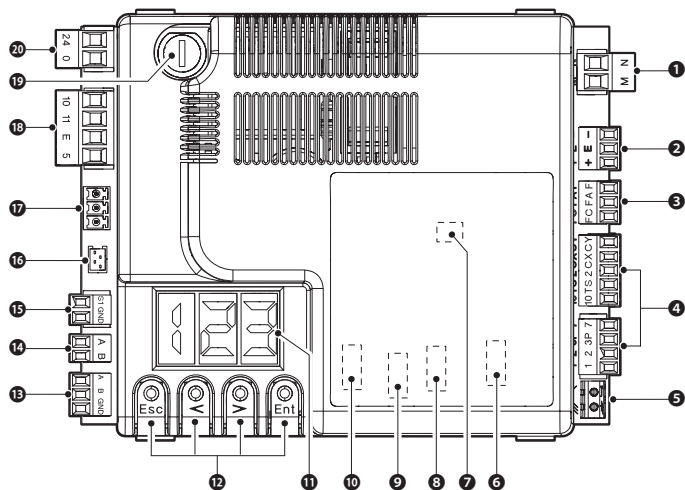

Remove the card cover before inserting the cards into the connectors.

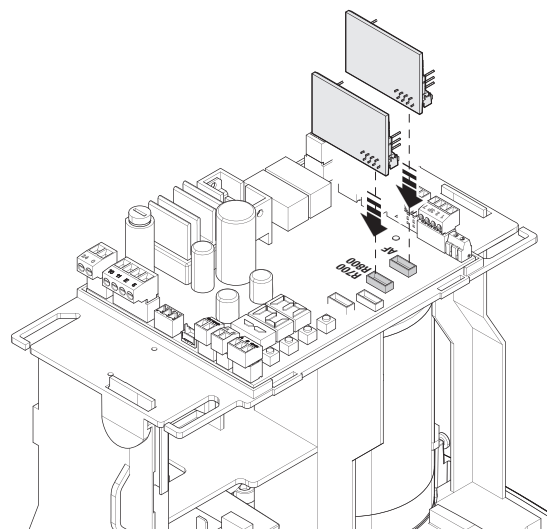
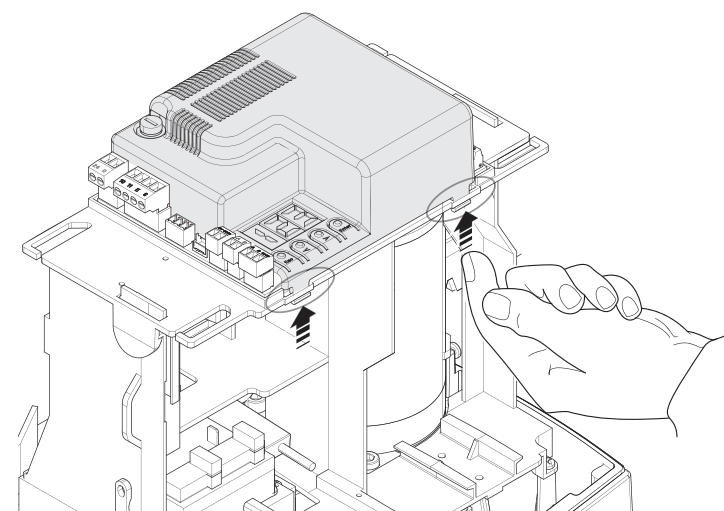

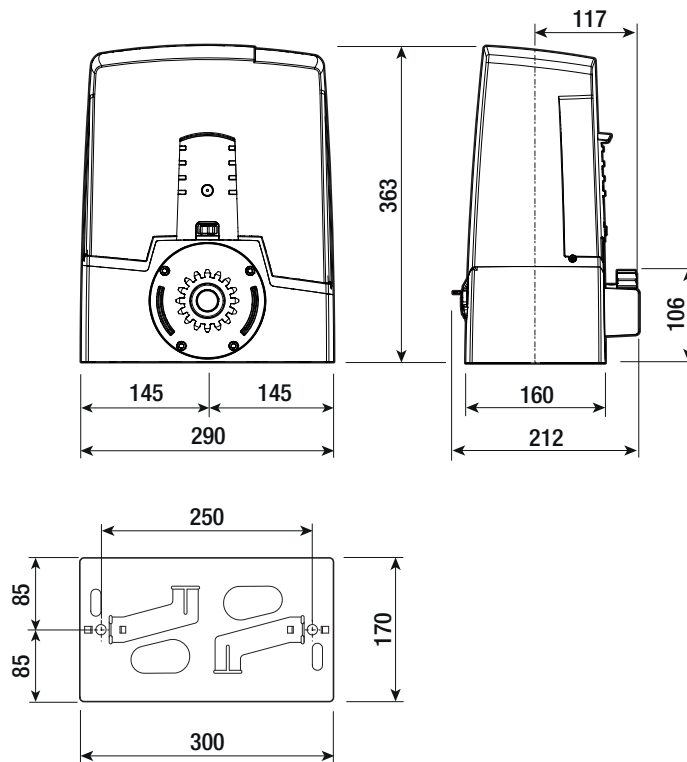

**Usage limitations**

MODELS	BXV04AGS	BXV06AGS	BXV08AGS	BXV10AGS	BXV04RGS	BXV06RGS	BXV08RGS	BXV10RGS
Pinion module	4	4	4	4	4	4	4	4
Maximum gate-leaf length (m)	14	18	20	20	14	18	20	20
Maximum gate-leaf weight (kg)	400	600	800	1000	400	600	800	1000

MODELS	BXV06AGM	BXV10AGM	BXV04ALS	BXV06ALS	BXV08ALS	BXV10ALS
Pinion module	4	4	4	4	4	4
Maximum gate-leaf length (m)	18	20	14	18	20	20
Maximum gate-leaf weight (kg)	600	1000	400	600	800	1000

**Fuse table**

MODELS	BXV04AGS	BXV06AGS	BXV08AGS	BXV10AGS	BXV04RGS	BXV06RGS	BXV08RGS	BXV10RGS
Line fuse	1.6 A-F	1.6 A-F	1.6 A-F	1.6 A-F	3.15 A-F	3.15 A-F	3.15 A-F	3.15 A-F
Accessories fuse	2 A-F	2 A-F	2 A-F	2 A-F	2 A-F	2 A-F	2 A-F	2 A-F

MODELS	BXV06AGM	BXV10AGM	BXV04ALS	BXV06ALS	BXV08ALS	BXV10ALS
Line fuse	1.6 A-F	1.6 A-F	1.6 A-F	1.6 A-F	1.6 A-F	1.6 A-F
Accessories fuse	2 A-F	2 A-F	2 A-F	2 A-F	2 A-F	2 A-F



## Technical data

MODELS	BXV04AGS	BXV06AGS	BXV08AGS	BXV10AGS	BXV04RGS	BXV06RGS	BXV08RGS	BXV10RGS
Power supply (V - 50/60 Hz)	230 AC	230 AC	230 AC	230 AC	110 AC	110 AC	110 AC	110 AC
Motor power supply (V)	24 DC	24 DC	24 DC	24 DC	24 DC	24 DC	24 DC	24 DC
Standby consumption (W)	5,5	5,5	5,5	5,5	5,5	5,5	5,5	5,5
Power (W)	170	270	400	400	170	270	400	400
Maximum current draw (mA)	7	11	16	16	7	11	16	16
Colour	RAL 7024	RAL 7024	RAL 7024	RAL 7024	RAL 7024	RAL 7024	RAL 7024	RAL 7024
Operating temperature (°C)	-20 ÷ +55	-20 ÷ +55	-20 ÷ +55	-20 ÷ +55	-20 ÷ +55	-20 ÷ +55	-20 ÷ +55	-20 ÷ +55
Thrust (N)	350	600	800	1000	350	600	800	1000
Maximum operating speed (m/min)	12	12	11	11	12	12	11	11
Operating time (s)	180	180	180	180	180	180	180	180
Duty cycle	HEAVY-DUTY SERVICE	HEAVY-DUTY SERVICE	HEAVY-DUTY SERVICE	HEAVY-DUTY SERVICE	HEAVY-DUTY SERVICE	HEAVY-DUTY SERVICE	HEAVY-DUTY SERVICE	HEAVY-DUTY SERVICE
Protection rating (IP)	44	44	44	44	44	44	44	44
Insulation class	I	I	I	I	I	I	I	I

MODELS	BXV06AGM	BXV10AGM	BXV04ALS	BXV06ALS	BXV08ALS	BXV10ALS
Power supply (V - 50/60 Hz)	230 AC	230 AC	230 AC	230 AC	230 AC	230 AC
Motor power supply (V)	24 DC	24 DC	24 DC	24 DC	24 DC	24 DC
Standby consumption (W)	5,5	5,5	5,5	5,5	5,5	5,5
Power (W)	270	400	170	270	400	400
Maximum current draw (mA)	11	16	7	11	16	16
Colour	RAL 7024	RAL 7024	RAL 7040	RAL 7040	RAL 7040	RAL 7040
Operating temperature (°C)	-20 ÷ +55	-20 ÷ +55	-20 ÷ +55	-20 ÷ +55	-20 ÷ +55	-20 ÷ +55
Thrust (N)	600	1000	350	600	800	1000
Maximum operating speed (m/min)	12	11	12	12	11	11
Operating time (s)	180	180	180	180	180	180
Duty cycle	HEAVY-DUTY SERVICE	HEAVY-DUTY SERVICE	HEAVY-DUTY SERVICE	HEAVY-DUTY SERVICE	HEAVY-DUTY SERVICE	HEAVY-DUTY SERVICE
Protection rating (IP)	44	44	44	44	44	44
Insulation class	I	I	I	I	I	I

## Cable types and minimum thicknesses

Cable length (m)	up to 20	from 20 to 30
Power supply 230 V AC	3G x 1.5 mm <sup>2</sup>	3G x 2.5 mm <sup>2</sup>
24 V AC/DC flashing beacon	2 x 1 mm <sup>2</sup>	2 x 1 mm <sup>2</sup>
TX Photocells	2 x 0.5 mm <sup>2</sup>	2 x 0.5 mm <sup>2</sup>
RX photocells	4 x 0.5 mm <sup>2</sup>	4 x 0.5 mm <sup>2</sup>
Command and control devices	* no. x 0.5 mm <sup>2</sup>	* no. x 0.5 mm <sup>2</sup>

\* no. = see product assembly instructions - Warning: the cable cross-section is indicative and varies according to the motor power and cable length.

 When operating at 230 V and outdoors, use H05RN-F cables compliant with 60245 IEC 57 (IEC); when operating indoors, use H05VV-F cables compliant with 60227 IEC 53 (IEC). For power supplies up to 48 V, you can use FROR 20-22 II cables compliant with EN 50267-2-1 (CEI).

 To connect the antenna, use RG58 cable (up to 5 m).

 For paired connection and CRP, use UTP CAT5 cable (up to 1,000 m).

 If the cable lengths differ from those specified in the table, define the cable cross-sections according to the actual power draw of the connected devices and in line with regulation CEI EN 60204-1.

 For multiple, sequential loads along the same line, recalculate the values in the table according to the actual power draw and distances. For information on connecting products not covered in this manual, please see the documentation accompanying the products themselves.

## INSTALLATION

 The following illustrations are examples only. The space available for fitting the operator and accessories varies depending on the area where it is installed. It is up to the installer to find the most suitable solution.

 The drawings show an operator fitted on the left.

### Preliminary operations

Dig a hole for the foundation frame.

Set up the corrugated tubes needed for the wiring coming out of the junction pit.

 Use  $\varnothing$  40 mm corrugated tubes to connect the gearmotor to the accessories.

 Prepare a  $\varnothing$  20 mm tube to run the release cord through. **A**

 The number of tubes depends on the type of system and the accessories that are going to be fitted.

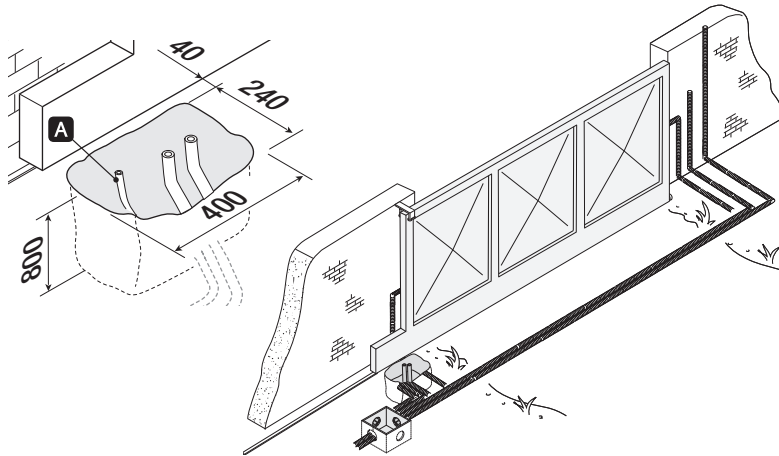

### Laying the anchoring plate

Set up a foundation frame that is larger than the anchoring plate.

Insert the foundation frame into the dug hole.

 The foundation frame must protrude by 50 mm, above ground level.

Fit an iron cage in the foundation frame to reinforce the concrete.

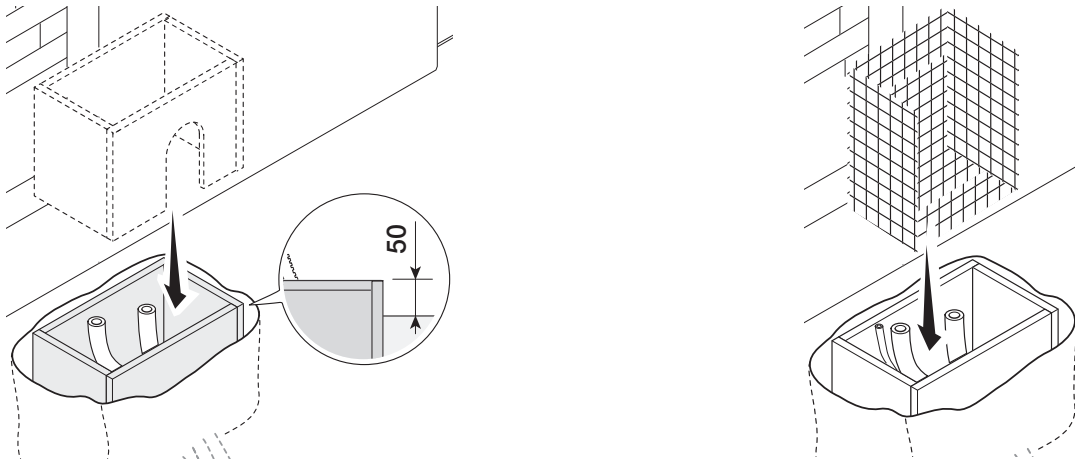

Insert the screws supplied in the anchoring plate.  
 Lock the screws in place with the nuts supplied.  
 Remove the pre-shaped clamps using a screwdriver.  
 Fit the anchoring plate in the iron cage.

The tubes must pass through the existing holes.

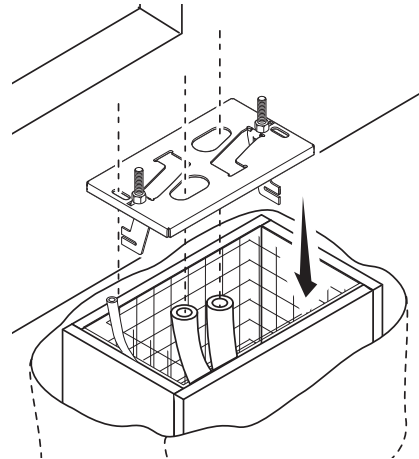
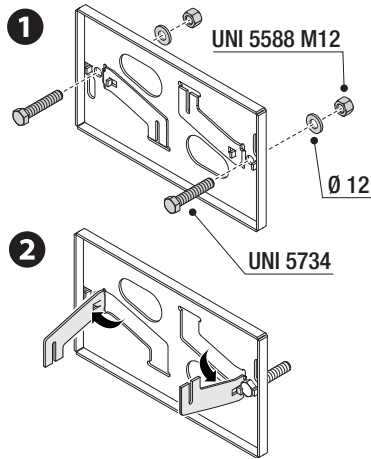

Position the anchoring plate, taking note of the measurements shown in the drawing.

If the gate does not have a rack, proceed with the installation.

See the section "FASTENING THE RACK".

Cast cement into the foundation frame.

The plate must be perfectly level and the screw threads completely above surface.

Wait at least 24 hours for the cement to dry.

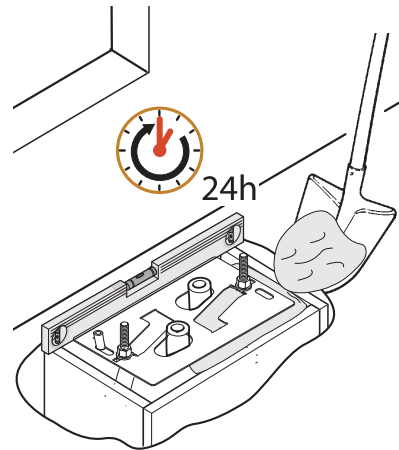
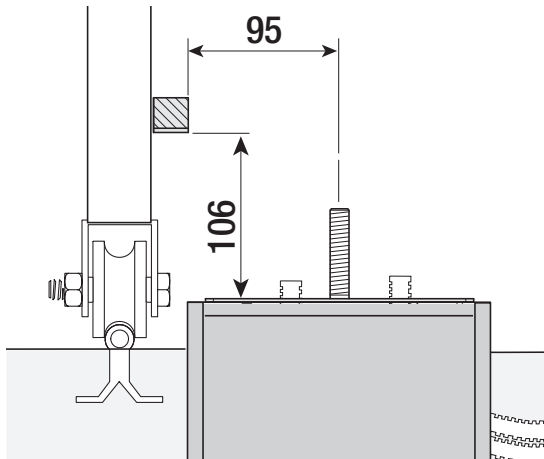

Remove the foundation frame.

Fill the hole with soil around the concrete block.

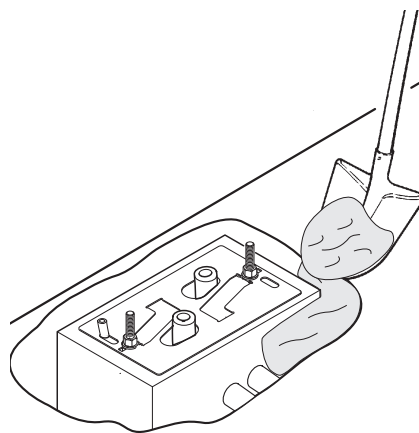
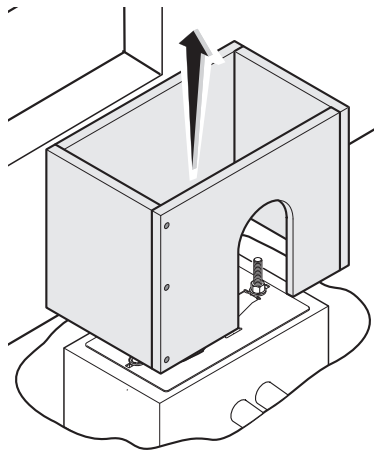

Remove the nuts from the screws.  
 Insert the electrical cables into the tubes until they protrude by about 600 mm.

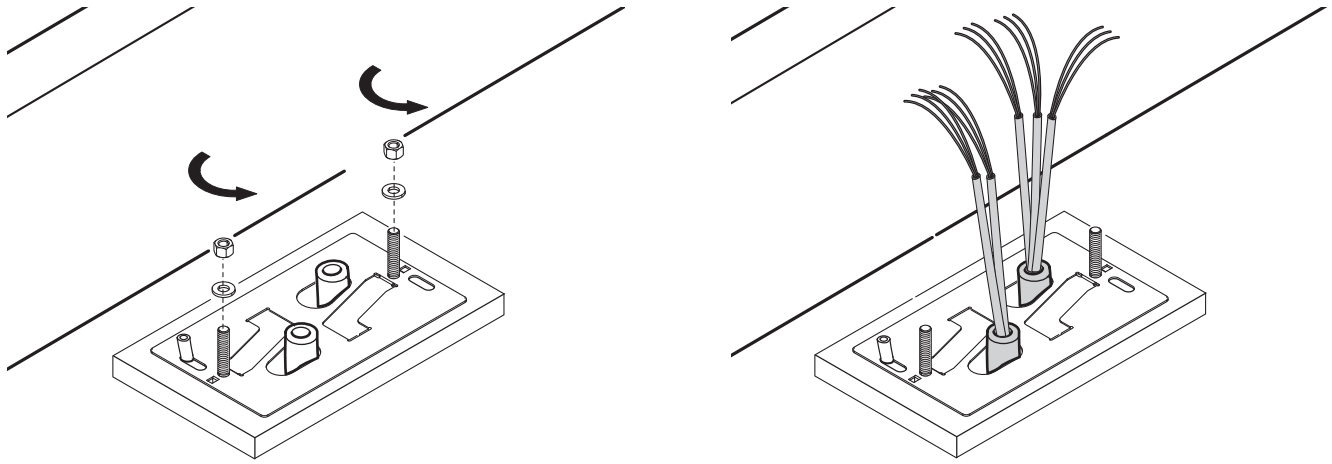

## Setting up the operator

Remove the operator cover.  
 Place the operator on top of the anchoring plate.

 The electrical cables must pass under the operator foundation frame

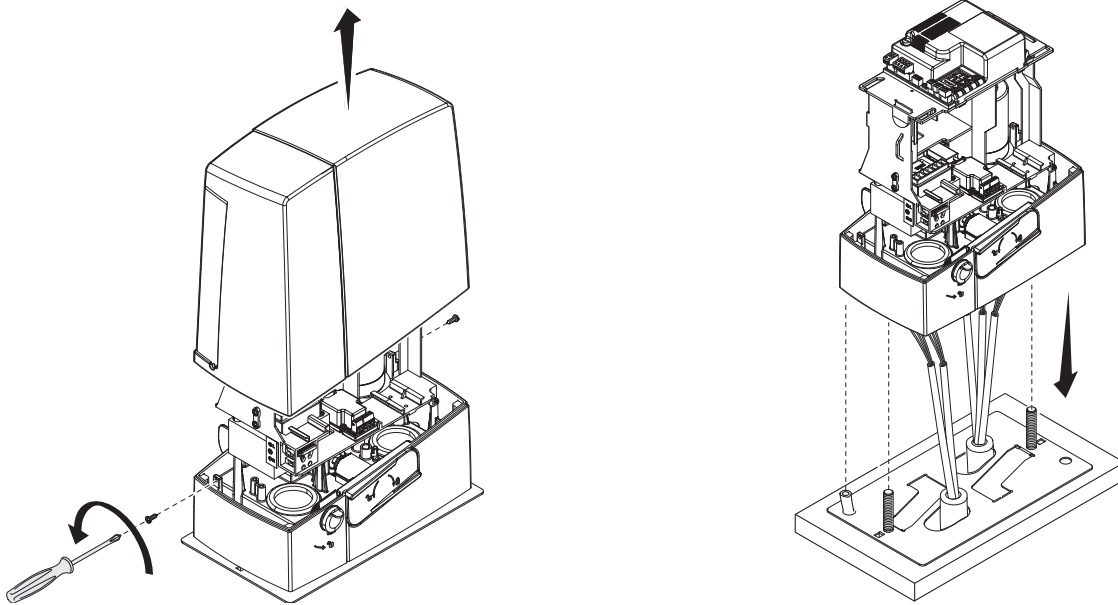

Make a hole in the cable gland.  
 Thread the cables through the cable gland.  
 Lift the operator by 5-10 mm from the plate by adjusting the threaded feet, to allow for any adjustments that may need to be made between the rack and pinion.

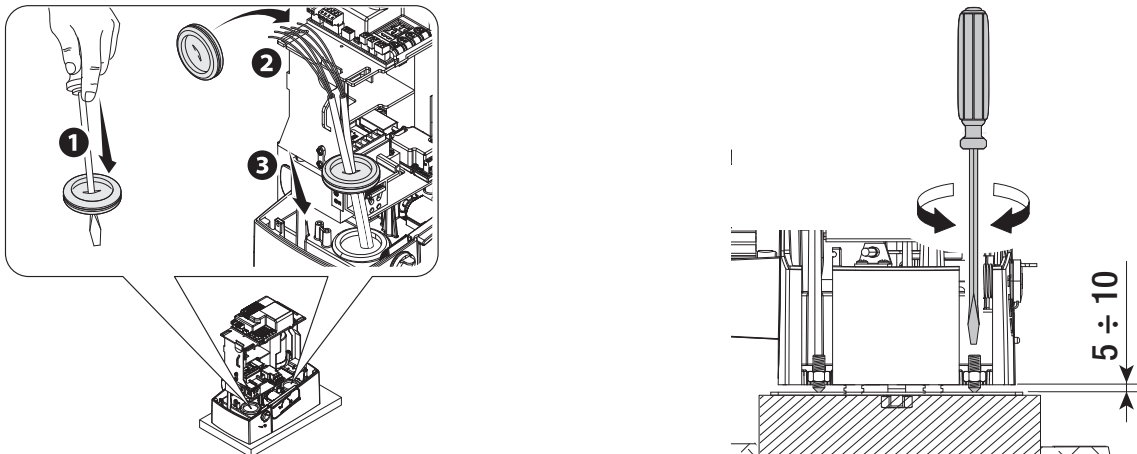

## Fastening the rack

- 1 Release the operator.
- 2 Rest the rack on the pinion.
- 3 Weld or fasten the rack to the gate along its entire length.

 To assemble the rack modules, use an extra piece and rest it under the joint, then fasten it in place using two clamps.

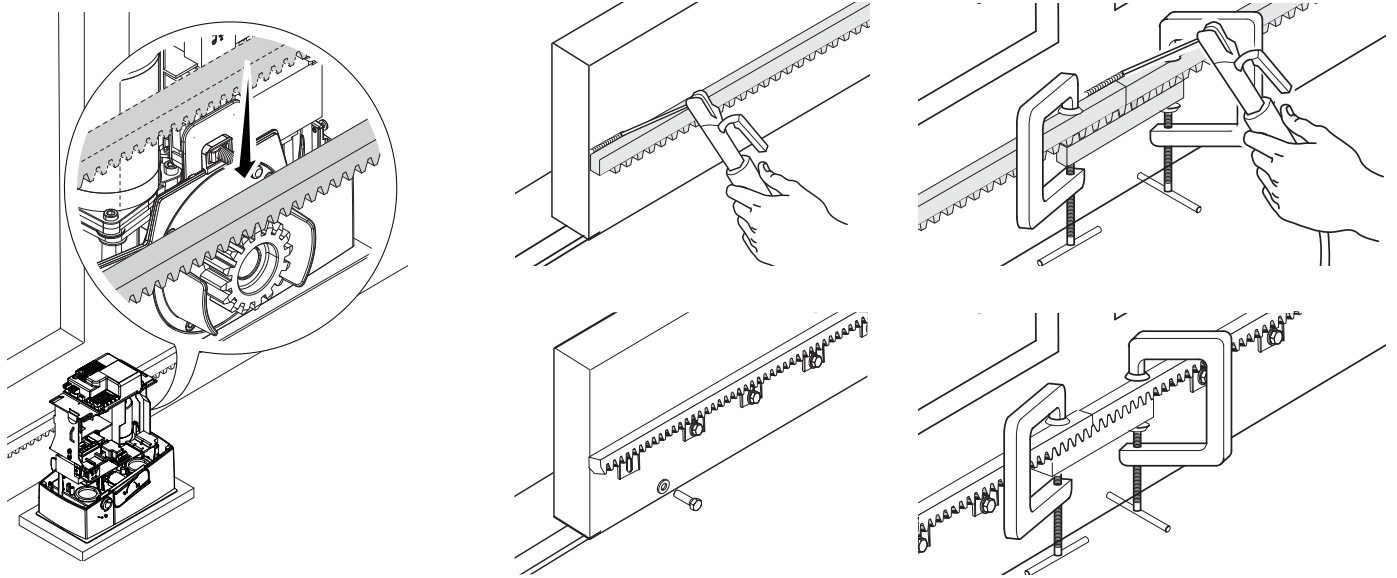

## Adjusting the pinion-rack coupling

Open and close the gate manually.

Adjust the pinion-rack coupling distance using the threaded feet (vertical adjustment) and the holes (horizontal adjustment).

 The weight of the gate must not bear down upon the operator.

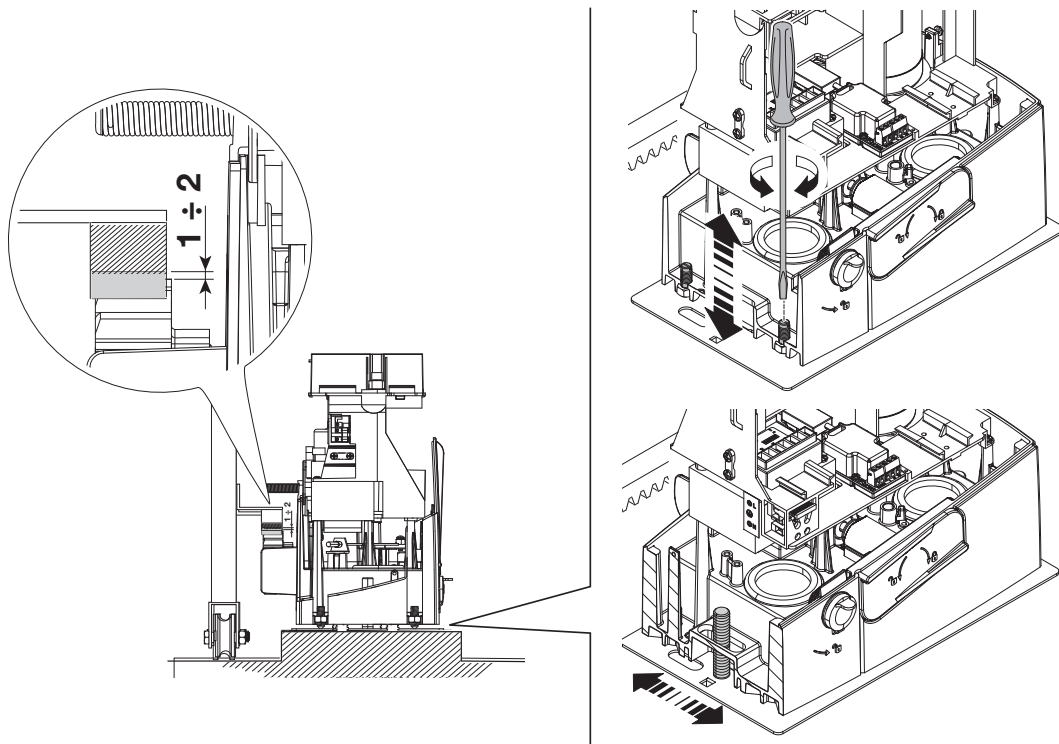

## Fastening the operator in place

 Only fasten the operator after adjusting the pinion-rack coupling.  
Fasten the operator to the anchoring plate using stoppers and nuts.

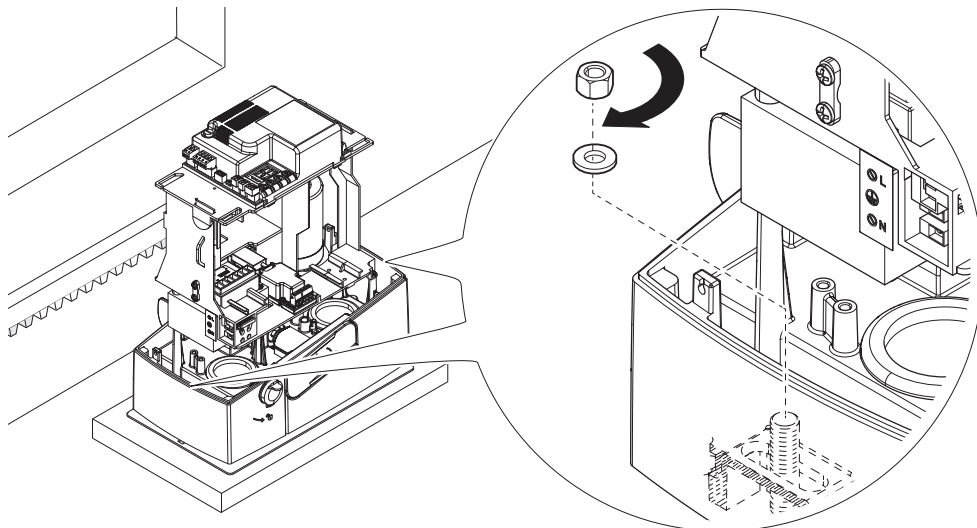

## Determining the travel end points with mechanical limit switches

- 1 Open the gate.
- 2 Insert the opening limit-switch tab in the rack.
- 3 Fasten the opening limit-switch tab using the grub screws supplied.

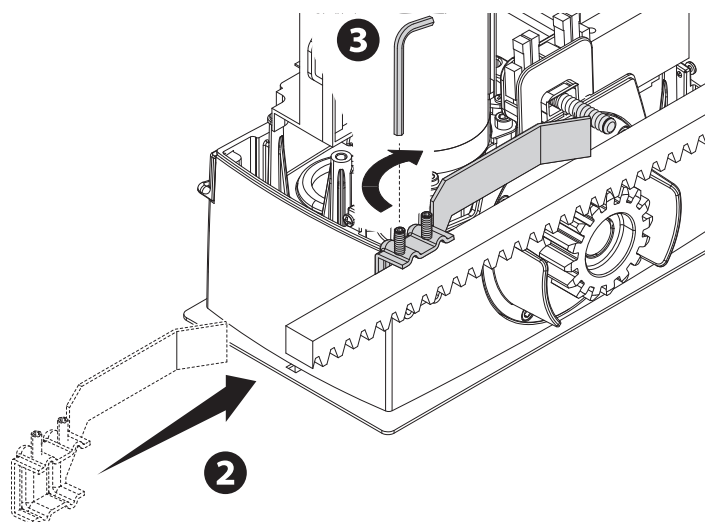
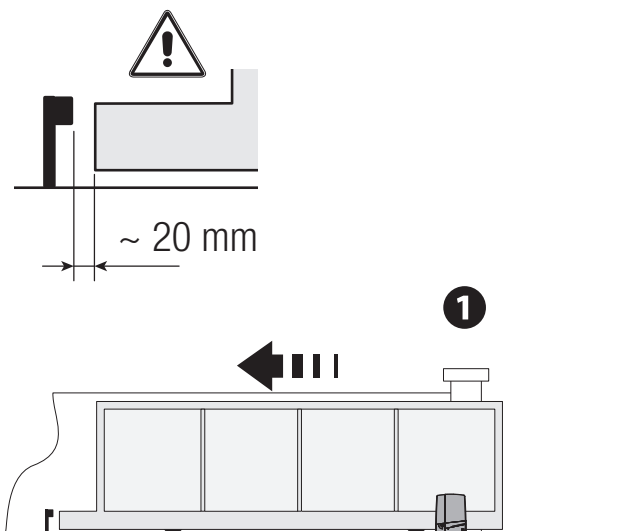

- 4 Close the gate.
- 5 Insert the closing limit-switch tab in the rack. The spring must trigger the microswitch.
- 6 Fasten the closing limit-switch tab using the grub screws supplied.

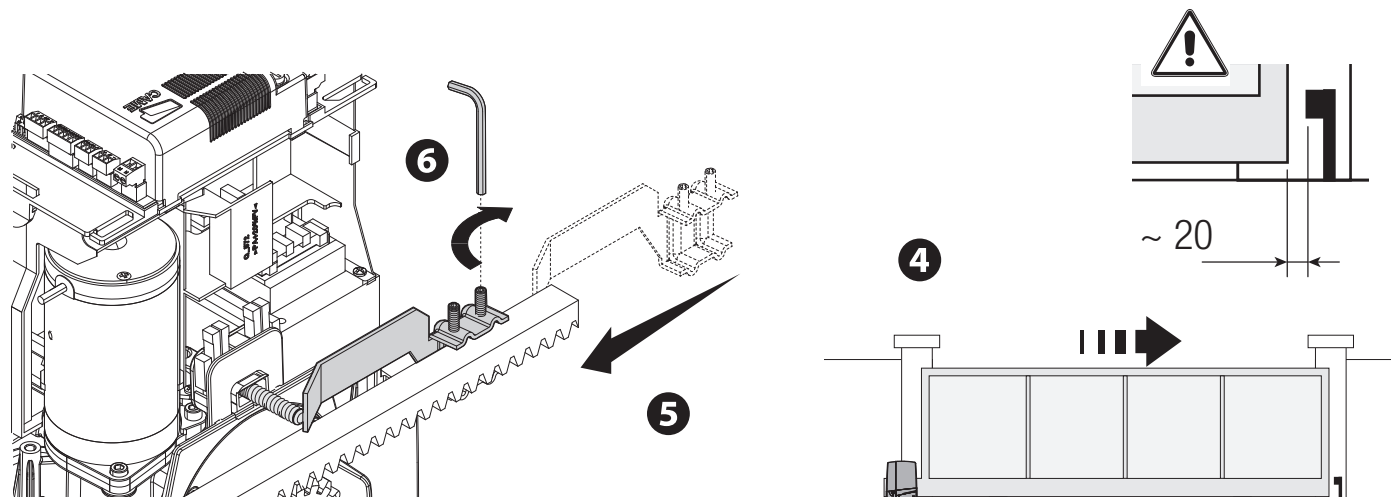

### Establishing the limit-switch points with magnetic limit switches

\* Only for BXV06AGM and BXV10AGM

- A Magnetic limit-switch fins during closing
- B Magnetic limit-switch fins during opening

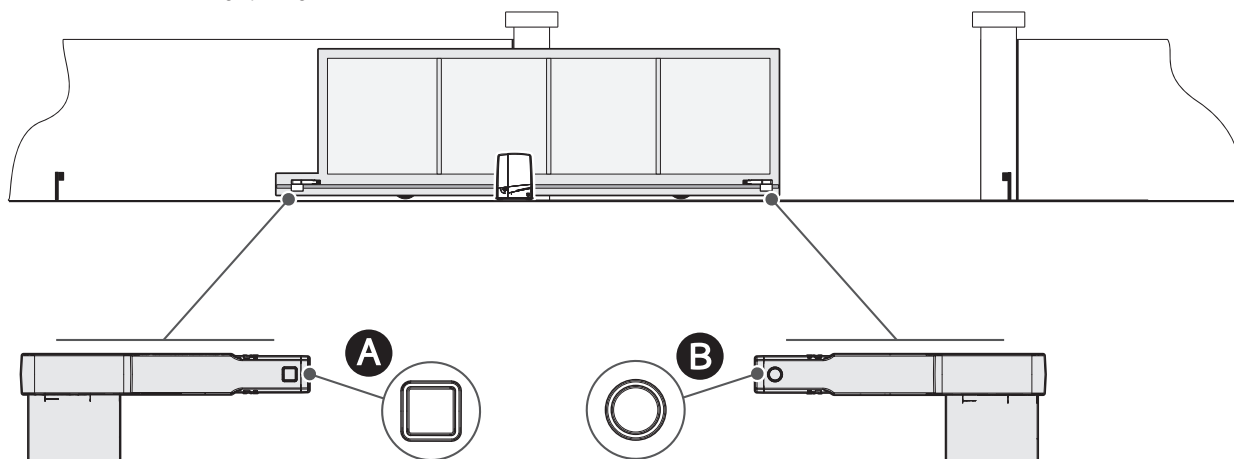

Open the gate.  
Insert the magnetic opening limit-switch fin on the rack.

The fin magnet must be between 10 and 30 mm from the magnetic sensor.

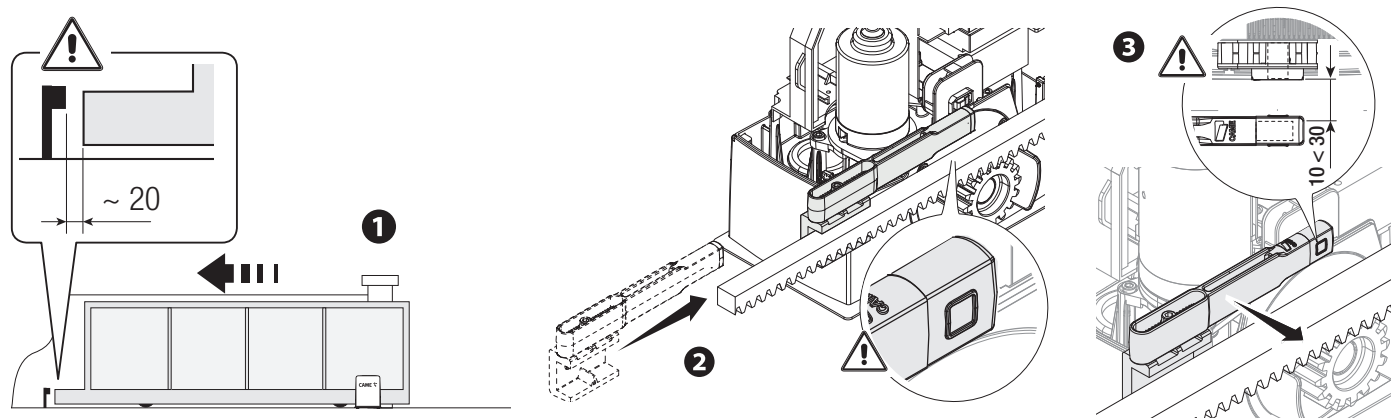

Fasten the support to the rack using the grub screws supplied.

 The limit-switch fin magnet must be perpendicular to the magnetic sensor.

Fasten the limit-switch fin using the screw (supplied).

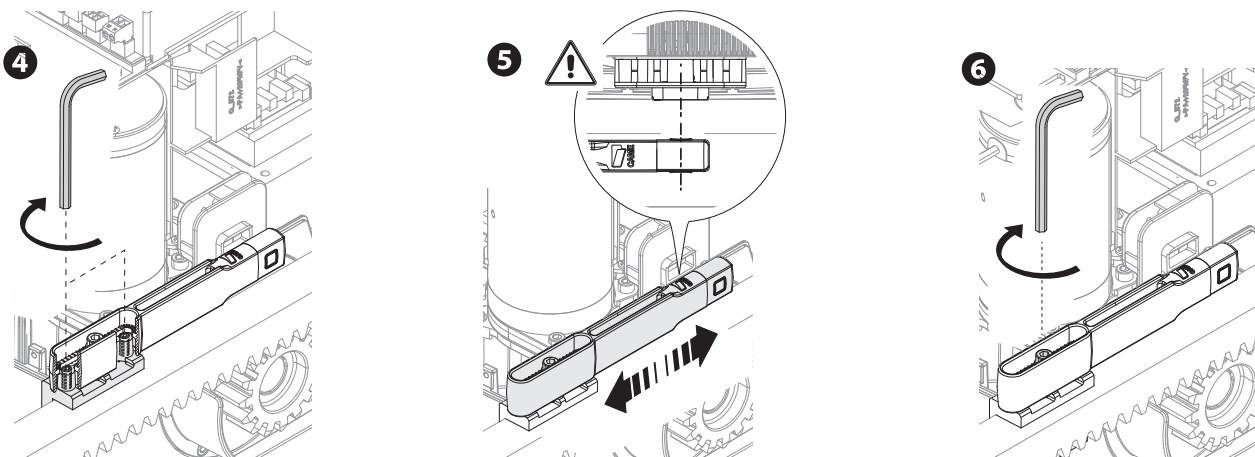

Close the gate.

Insert the magnetic closing limit-switch fin on the rack.

 The fin magnet must be between 10 and 30 mm from the magnetic sensor.

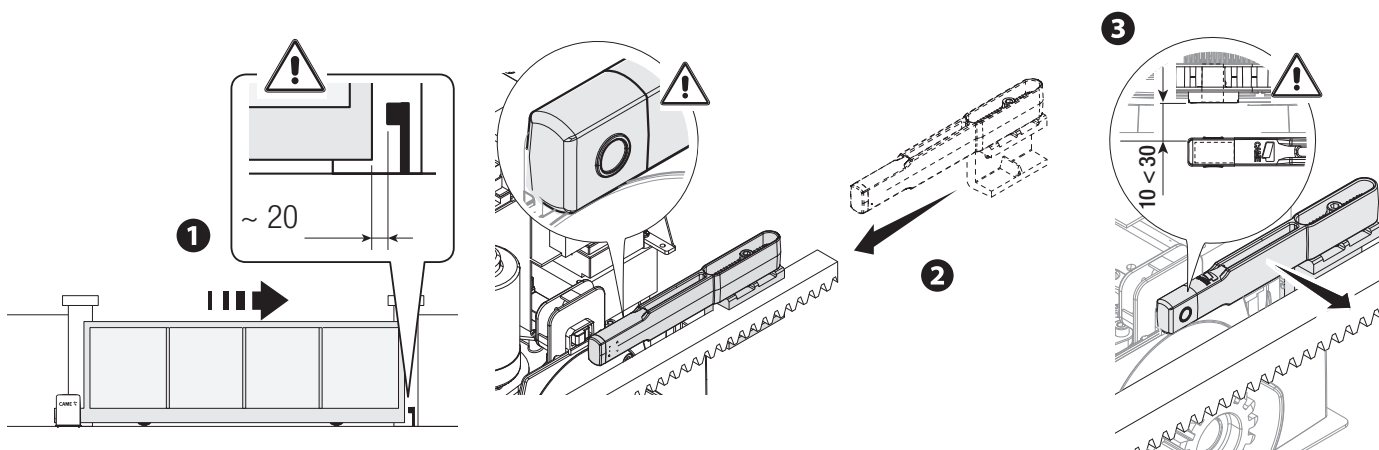

Fasten the support to the rack using the grub screws supplied.

 The limit-switch fin magnet must be perpendicular to the magnetic sensor.

Fasten the limit-switch fin using the screw (supplied).

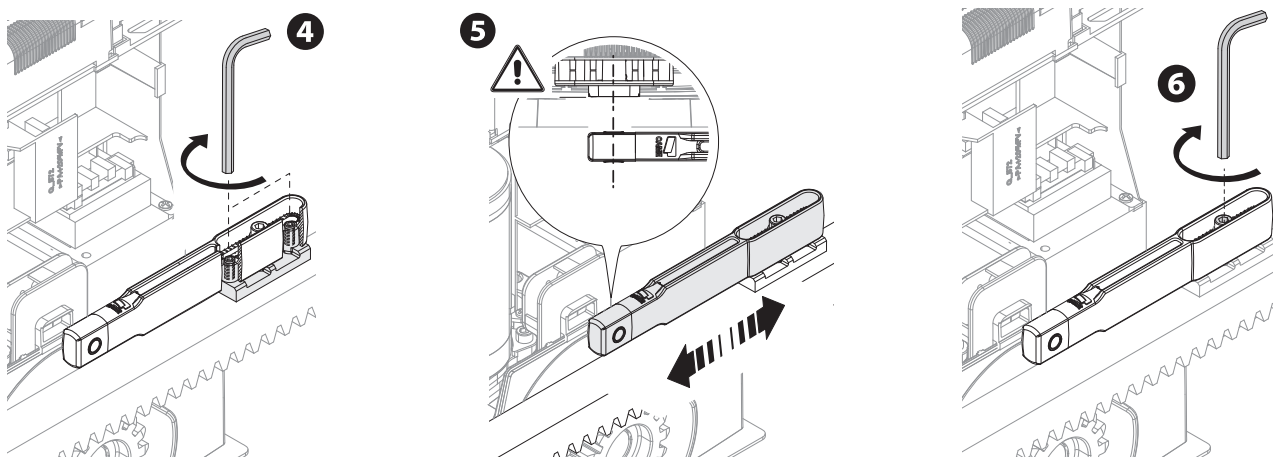



Passing the electrical cables

- Connect all wires and cables in compliance with the law. The electrical cables must not touch any parts that may overheat during use (such as the motor and transformer).
- Use cable glands to connect the devices to the control panel. One of these must be used exclusively for the power supply cable.

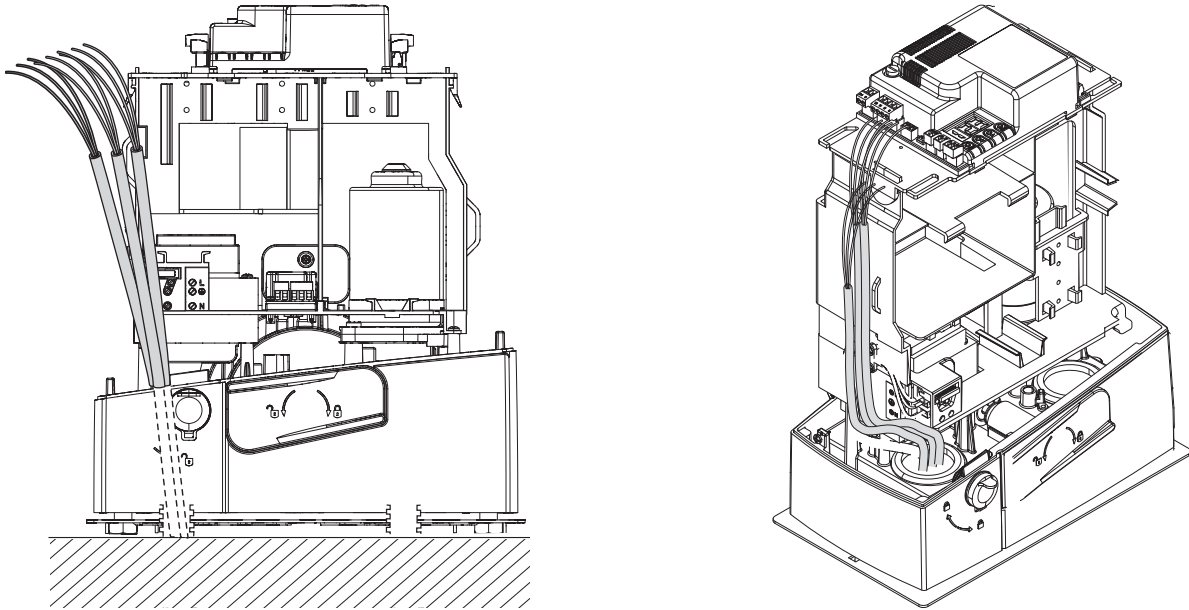

Power supply

Make sure the mains power supply is disconnected during all installation procedures.

⚠ Before working on the control panel, disconnect the mains power supply and remove the batteries, if any.

Connecting to the mains (120/230 V AC - 50/60 Hz)

- F Line fuse
- L Phase
- N Neutral
- ⊕ Earth

Power supply output for accessories

The output normally delivers 24 V AC.

📖 The sum of the connected accessories input must not exceed 40 W.

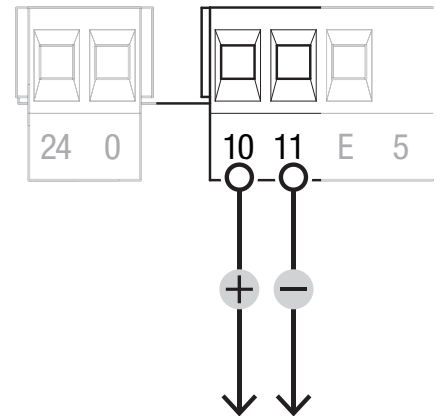
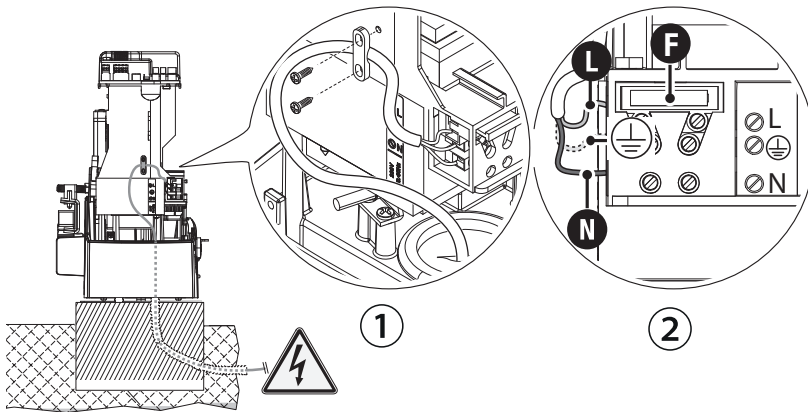

Maximum capacity of contacts

Device	Output	Power supply (V)	Power (W)
Accessories	10 - 11	24 AC	40
Additional light	10 - E	24 AC	25
Flashing beacon	10 - E	24 AC	25
Operator status warning light	10 - 5	24 AC	3

The outputs deliver 24 V DC when the batteries start operating, if they are installed.

## Signalling devices

### ❶ Additional light

It increases the light in the manoeuvring area.

### ❷ Flashing beacon

It flashes when the operator opens and closes.

### ❸ Operator status warning light

It notifies the user of the operator status.

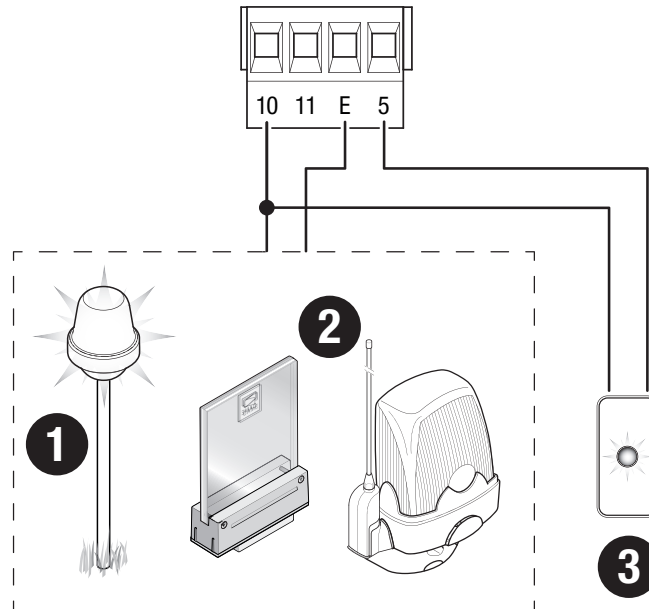

## Command and control devices

### 1 Antenna with RG58 cable

### 2 STOP button (NC contact)

It stops the gate and excludes automatic closing. Use a control device to resume movement.

If the contact is not used, it must be deactivated during programming.

### 3 Control device (NO contact)

OPEN ONLY or PARTIAL OPENING function

Fully or partially open the gate.

When the [HOLD-TO-RUN] function is active, the control device must be connected during OPENING.

### 4 Control device (NO contact)

OPEN-CLOSE (step-by-step) or OPEN-STOP-CLOSE-STOP (sequential) function

When the [HOLD-TO-RUN] function is active, the control device must be connected during CLOSING.

### 5 Card reader

### 6 Transponder selector switch

### 7 Keypad selector

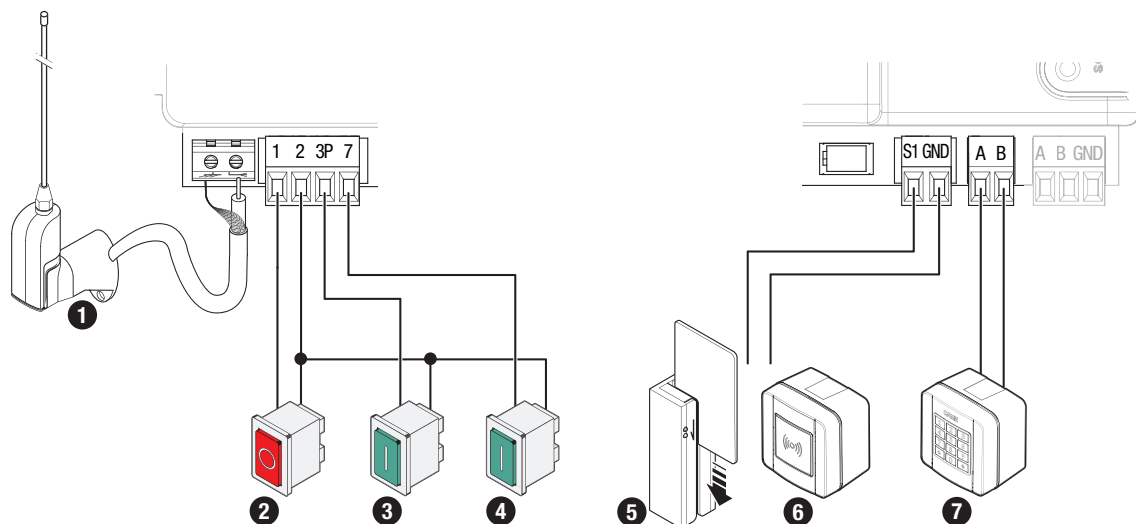

## Safety devices

Connect the safety devices to the CX, CY and/or CZ inputs (NC contacts).

During programming, configure the type of action that must be performed by the device connected to the input.

If contacts CX and/or CY are not used, they must be deactivated during programming.

### DELTA photocells

Standard connection

### DELTA photocells

Connection with safety test

See function F5, safety devices test.

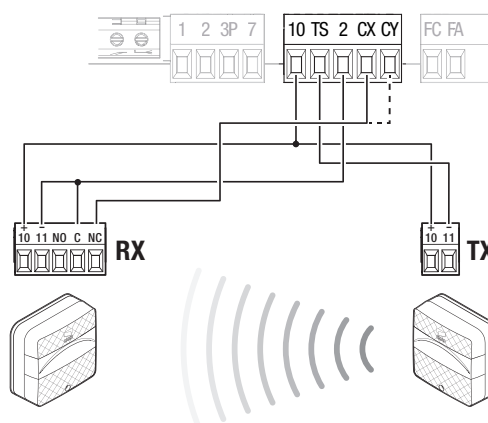
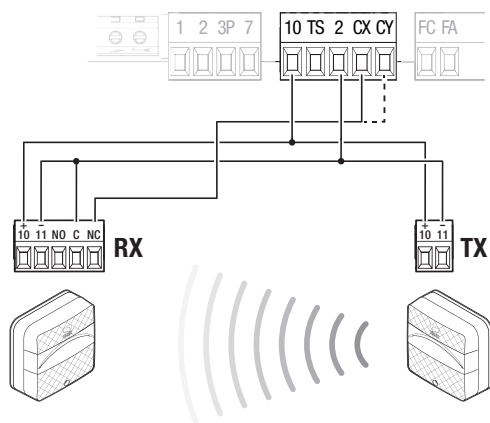

## DIR / DELTA-S photocells

Standard connection

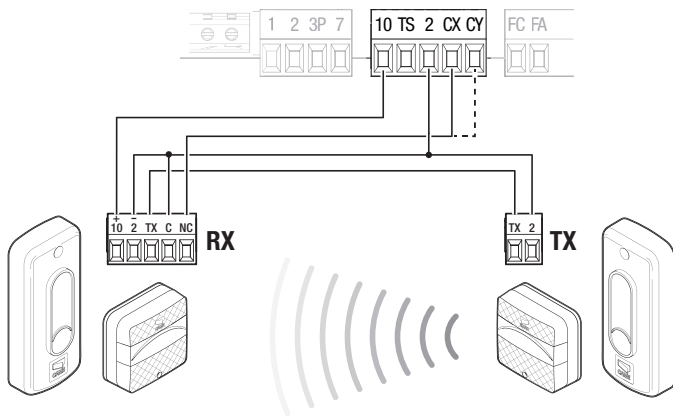

## DIR / DELTA-S photocells

Connection with safety test

See function F5, safety devices test.

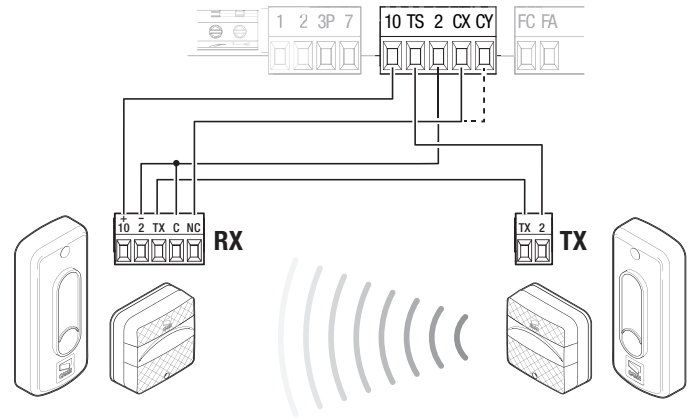

## DFWN sensitive edge

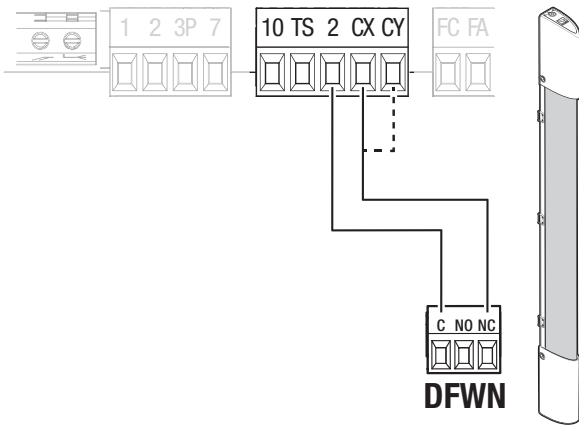

Programming button functions

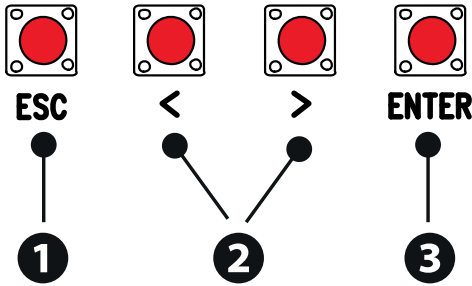
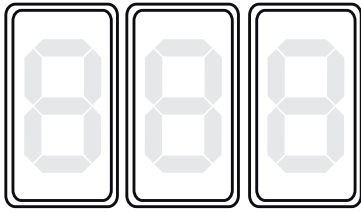

**1 ESC button**

- The ESC button is used to perform the operations described below.
- Exit the menu
- Delete the changes
- Go back to the previous screen
- Stop the operator

**2 <> buttons**

- The <> buttons are used to perform the operations described below.
- Navigate the menu
- Increase or decrease values
- Open or close the operator

**3 ENTER button**

- The ENTER button is used to perform the operations described below.
- Access menus
- Confirm a choice

Getting started

Once the electrical connections have been made, proceed with commissioning. Only skilled and qualified staff may perform this operation. Make sure that there are no obstacles in the way. Power up the device and begin programming. Start programming with the F54 function (opening direction).

After powering up the system, the first manoeuvre is always to open the gate; Wait for the manoeuvre to be completed.

Press the STOP button immediately in the event of any faults, malfunctions, strange noises or vibrations, or unexpected behaviour in the system.

If the three display segments are flashing, calibrate the travel.

Functions menu

**Total stop**

It stops the gate and excludes automatic closing. Use a control device to resume movement.

F1	Total stop	OFF (Default) ON
----	------------	---------------------

**CX input**

Associate a function with the CX input.

F2	CX input	OFF (Default) C1 = Reopen while closing (photocells) C2 = Reclose while opening (photocells) C3 = Partial stop Only with [Automatic close] activated. C4 = Obstacle standby (photocells) C7 = Reopening during closure (sensitive edges) C8 = Reclose while opening (sensitive edges)
----	----------	---

**CY input**

Associate a function with the CY input.

F3	CY input	OFF (Default) C1 = Reopen while closing (photocells) C2 = Reclose while opening (photocells) C3 = Partial stop Only with [Automatic close] activated. C4 = Obstacle standby (photocells) C7 = Reopening during closure (sensitive edges) C8 = Reclose while opening (sensitive edges)
----	----------	---

### Safety devices test

Check that the photocells connected to the inputs are operating correctly, after each opening and closing command.

<b>F5</b>	<b>Safety devices test</b>	0 = Deactivated (Default) 1 = CX 2 = CY 4 = CX+CY
-----------	----------------------------	--

### Hold-to-run

With the function active, the operator stops moving (opening or closing) when the control device is released.

 When the function is active, it excludes all other control devices.

<b>F6</b>	<b>Hold-to-run</b>	0 = Deactivated (Default) 1 = Activated
-----------	--------------------	--

### Command 2-7

Associate a command with the device connected to 2-7.

<b>F7</b>	<b>Command 2-7</b>	0 = Step-by-step (default) 1 = Sequential 2 = Open 3 = Close
-----------	--------------------	---

### Command 2-3P

Associate a command to the connected device on 2-3P.

<b>F8</b>	<b>Command 2-3P</b>	1 = Partial opening  The partial opening time is set from the function [Partial opening time]. 2 = Open
-----------	---------------------	--

### Obstacle with motor stopped

With the function active, the gate remains idle if the safety devices detect an obstacle. The function is active when the gate is closed, open or after a complete stop.

<b>F9</b>	<b>Obstacle with motor stopped</b>	OFF (Default) ON
-----------	------------------------------------	---------------------

### Gate-open warning light

It signals the gate status.

<b>F10</b>	<b>Gate-open warning light</b>	0 = Warning light on (default) - The warning light stays on when the gate is moving or open. 1 = Warning light flashing - The warning light flashes every half second when the gate is opening and stays on when the gate is open. The light flashes every second when the gate is closing, and remains off when the gate is closed.
------------	--------------------------------	---

### Encoder

Manage operator slowdowns, obstacle detection and sensitivity.

<b>F11</b>	<b>Encoder</b>	OFF ON (Default)
------------	----------------	---------------------

### Soft start

Set a slowdown of a few seconds after each opening and closing command.

F12	Soft start	OFF (Default) ON
-----	------------	---------------------

### Sensor type

Set the type of control device.

F14	Sensor type	0 = Transponder selector switch 1 = Keypad selector (default)
-----	-------------	--

### Additional light

Choose the operating mode of the lighting device connected to the output.

F18	Additional light	0 =Flashing beacon (Default) 1 = Cycle light.  The light remains off if an automatic closing time is not set.
-----	------------------	--

### Automatic closure

Set the time before automatic closure is activated, once the opening travel end has been reached.

 The function does not work if any of the safety devices are triggered when an obstacle is detected, or after a complete stop, or during a power outage.

F19	Automatic closure	OFF (Default) From 1 to 180 seconds
-----	-------------------	--

### Automatic closing after partial opening

Set the time before automatic closure is activated, after a partial opening command has been performed.

 The function does not work if any of the safety devices are triggered when an obstacle is detected, or after a complete stop, or during a power outage.

 Do not deactivate the function [Automatic close].

F20	Automatic closing after partial opening	OFF From 1 to 180 seconds (default: 10 seconds)
-----	---	--

### Pre-flashing time

Set the time for which the beacon is activated before each manoeuvre.

F21	Pre-flashing time	OFF (Default) From 1 to 10 seconds
-----	-------------------	---------------------------------------

### Gate travel speed

Set the travel speed (percentage of maximum speed).

F28	Gate travel speed	50% to 100% (Default 100%)
-----	-------------------	----------------------------

### Slowdown speed

Opening and closing slowdown speed

 This function appears only if the [Encoder] function is active.

F30	Slowdown speed	10% to 50% (Default 50%)
-----	----------------	--------------------------

### Travel sensitivity

Adjust the obstruction detection sensitivity during boom travel.

F34	Travel sensitivity	10% to 100% (Default 100%) - 10% = maximum sensitivity - 100% = minimum sensitivity
-----	--------------------	---

### Slowdown sensitivity

Adjust the obstacle-detection sensitivity level during slowdown.

 This function appears only if the [Encoder] function is active.

F35	Slowdown sensitivity	10% to 100% (Default 100%) - 10% = maximum sensitivity - 100% = minimum sensitivity
-----	----------------------	---

### Partial opening point

Determine the gate partial opening point, as a percentage of total travel.

 This function appears only if the [Encoder] function is active.

F36	Partial opening point	10% to 80% (Default 10%)
-----	-----------------------	--------------------------

### Opening slowdown point

Set the opening slowdown start point, as a percentage of total travel.

 This function appears only if the [Encoder] function is active.

F37	Opening slowdown point	10% to 60% (Default 25%)
-----	------------------------	--------------------------

### Closing slowdown point

Set the closing slowdown start point, as a percentage of total travel.

 This function appears only if the [Encoder] function is active.

F38	Closing slowdown point	10% to 60% (Default 25%)
-----	------------------------	--------------------------

### RSE

Configure the function to be performed by the card inserted in the RSE connector.

F49	RSE	0 =Deactivated (Default) 1 = Paired 3 = CRP
-----	-----	---

### Save data

Save user data, timings and configurations to the memory device (memory roll or USB key).

 The function is displayed only when a USB stick is inserted into the USB port or when a memory roll card is inserted into the control board.

F50	Save data	0 =Deactivated (Default) 1 = Activated
-----	-----------	---

### Read data

Upload user data, timings and configurations from the memory device (memory roll or USB key).

 The function is displayed only when a USB stick is inserted into the USB port or when a memory roll card is inserted into the control board.

F51	Read data	0 =Deactivated (Default) 1 = Activated
-----	-----------	---



### Transferring MASTER-SLAVE parameters

Enable sharing for the parameters programmed on the master gate with the slave gate.

 This function appears only if the [RSE] function is active.

<b>F52</b>	<b>Transferring MASTER-SLAVE parameters</b>	OFF (Default) ON
------------	---	---------------------

### Opening direction

Set the gate opening direction.

<b>F54</b>	<b>Opening direction</b>	0 = To the left (default) 1 = To the right
------------	--------------------------	---

### CRP address

Assign a unique identification code (CRP address) to the control board. It is used where there are multiple operators connected via CRP.

<b>F56</b>	<b>CRP address</b>	from 1 to 255
------------	--------------------	---------------

### RSE speed

Set the remote connection system communication speed on the RSE port.

<b>F63</b>	<b>RSE speed</b>	0 = 1200 bps 1 = 2400 bps 2 = 4800 bps 3 = 9600 bps 4 = 14400 bps 5 = 19200 bps 6 = 38400 bps (default) 7 = 57600 bps 8 = 115200 bps
------------	------------------	--

### RIO ED T1

Associate one of the available functions to a wireless safety device.

The function only appears if there is an interface board for wireless devices.

<b>F65</b>	<b>RIO ED T1</b>	OFF (Default) P0 = It stops the gate and excludes automatic closing. Use a control device to resume movement. P7 = Reopen while closing. P8 = Reclose while opening.
------------	------------------	---

### RIO ED T2

Associate one of the available functions to a wireless safety device.

The function only appears if there is an interface board for wireless devices.

<b>F66</b>	<b>RIO ED T2</b>	OFF (Default) P0 = It stops the gate and excludes automatic closing. Use a control device to resume movement. P7 = Reopen while closing. P8 = Reclose while opening.
------------	------------------	---

### RIO PH T1

Associate one of the available functions to a wireless safety device.

The function only appears if there is an interface board for wireless devices.

<b>F67</b>	<b>RIO PH T1</b>	OFF (Default). P1 = Reopen while closing. P2 = Reclose while opening. P3 = Partial stop. P4 = Obstacle standby.
------------	------------------	---

### RIO PH T2

Associate one of the available functions to a wireless safety device.

The function only appears if there is an interface board for wireless devices.

<b>F68</b>	<b>RIO PH T2</b>	OFF (Default). P1 = Reopen while closing. P2 = Reclose while opening. P3 = Partial stop. P4 = Obstacle standby.
------------	------------------	---

### Partial opening time

Adjust the gate opening time.

<b>F71</b>	<b>Partial opening time</b>	From 5 to 40 seconds (default: 5 seconds)
------------	-----------------------------	---

### New user

Register up to a maximum of 250 users and assign a function to each one.

 The operation can be carried out by using a transmitter or another control device. The boards that manage the control devices (AF - R700 - R800) must be inserted into the connectors.

 Download the LIST OF REGISTERED USERS form from the docs.came.com portal by typing in L20180423.

<b>U1</b>	<b>New user</b>	1 = Step-by-step 2 = Sequential 3 = Open 4 = Partial opening  Choose the function to be assigned to the user. Press ENTER to confirm. Send the code from the control device. Repeat the procedure to add other users.
-----------	-----------------	---

### Remove user

Remove one of the registered users.

<b>U2</b>	<b>Remove user</b>	OFF ON  Use the arrows to choose the number associated with the user you want to remove. No.: 1 > 250 Alternatively, the control device associated with the user you want to remove can be activated. Press ENTER to confirm. "CLr" will appear to confirm deletion.
-----------	--------------------	---

### Remove all

Remove all registered users.

U3	Remove all	OFF (Default) ON
----	------------	---------------------

### Radio decoding

Choose the type of radio coding for the transmitters enabled to control the operator.

 If you choose the type of radio coding for the transmitters [Rolling code] or [TW key block], any transmitters with a different type of radio coding saved previously will be deleted.

U4	Radio decoding	1 = All decoding (default) 2 = Rolling code 3 = TW key block
----	----------------	--

### Motor type

Set the type of gearmotor installed.

A1	Motor type	1 = 400 kg 2 = 600 kg 3 = 800 kg 4 = 1000 kg
----	------------	---

### Travel calibration

Start the travel self-learning.

 This function appears only if the [Encoder] function is active.

A3	Travel calibration	OFF (Default) ON
----	--------------------	---------------------

### Parameter reset

Restore factory settings except for the functions: [Radio decoding], [Motor type] and the settings related to travel calibration.

A4	Parameter reset	OFF (Default) ON
----	-----------------	---------------------

### Manoeuvre counter

View the number of operator manoeuvres.

A5	Manoeuvre counter	001 = 100 manoeuvres 010 = 1000 manoeuvres 100 = 10000 manoeuvres 999 = 99900 manoeuvres CSI = Maintenance work
----	-------------------	---

### Adjusting the motor torque

Adjust the motor torque.

A6	Adjusting the motor torque	From 1 (minimum) to 5 (maximum)
----	----------------------------	---------------------------------

### FW version

Display the firmware version number and the GUI installed.

H1	FW version	
----	------------	--

## Import/export data

Save user data and system configuration data on a MEMORY ROLL card.

The stored data can be reused for another control board to configure another system in the same way.

**⚠** Before inserting and removing the MEMORY ROLL card, DISCONNECT THE MAINS POWER SUPPLY TO THE LINE.

- 1 Insert the MEMORY ROLL card into the corresponding connector on the control board.
- 2 Press the "Enter" button to access programming.
- 3 Use the arrows to choose the desired function.

 The functions are displayed only when a MEMORY ROLL card is inserted.

### - Save data

Save user data, timings and configurations to the memory device (memory roll or USB key).

### - Read data

Upload user data, timings and configurations from the memory device (memory roll or USB key).

 Once the data have been saved and loaded, remove the MEMORY ROLL card.

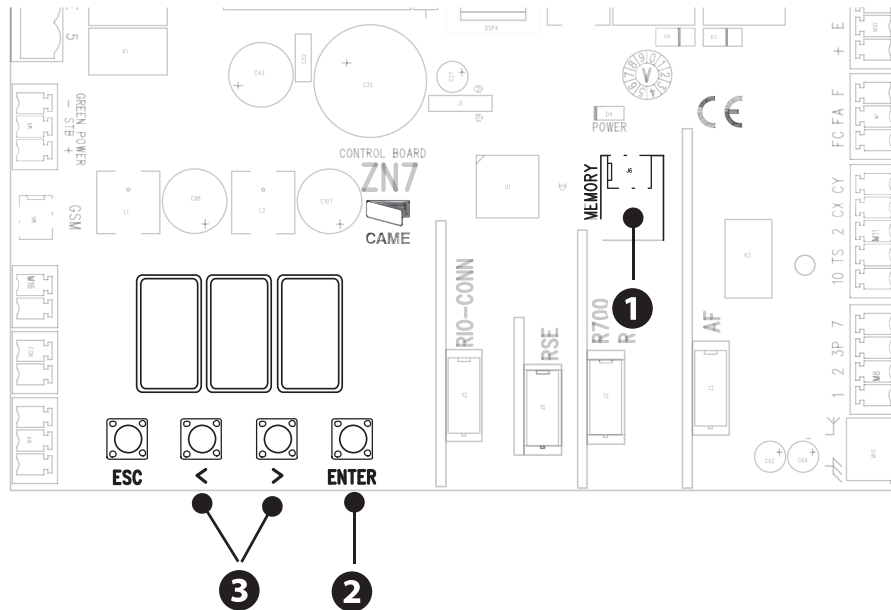

## ERROR MESSAGES

E1	Calibration error
E2	Adjustment error
E3	Encoder failure error
E4	Service test failure error
E7	Operating time error
E9	Obstacle detected during closing
E10	Obstacle detected during opening
E11	The maximum number of obstacles detected consecutively has been exceeded
E13	The limit switches are both open
E14	Serial communication error
E15	Incompatible transmitter error
E17	Wireless system communication error
E18	Wireless system not configured error

## FINAL OPERATIONS

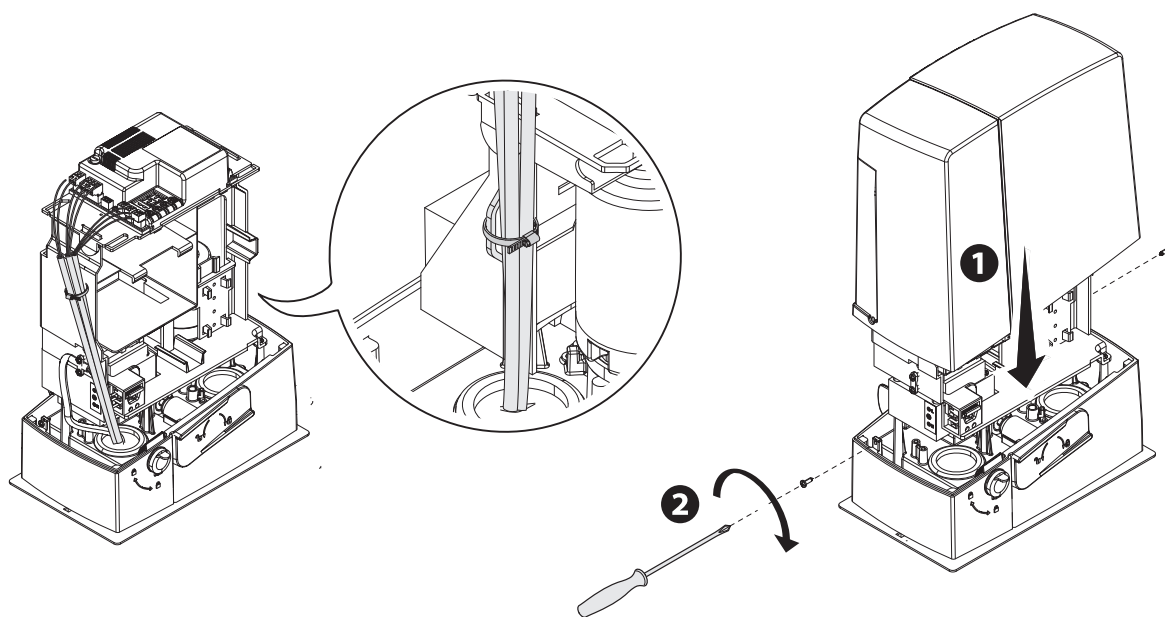

## PAIRED OPERATION

Two connected operators are controlled with one command.

### Electrical connections

Connect the two electronic boards with a UTP CAT 5 cable.

Insert an RSE card into both control boards.

Connect up the electrics for the devices and accessories.

 The devices and accessories must be connected to the control board which will be set as the MASTER.

 For information on connecting the electrics for the devices and accessories, please see the "ELECTRICAL CONNECTIONS" section.

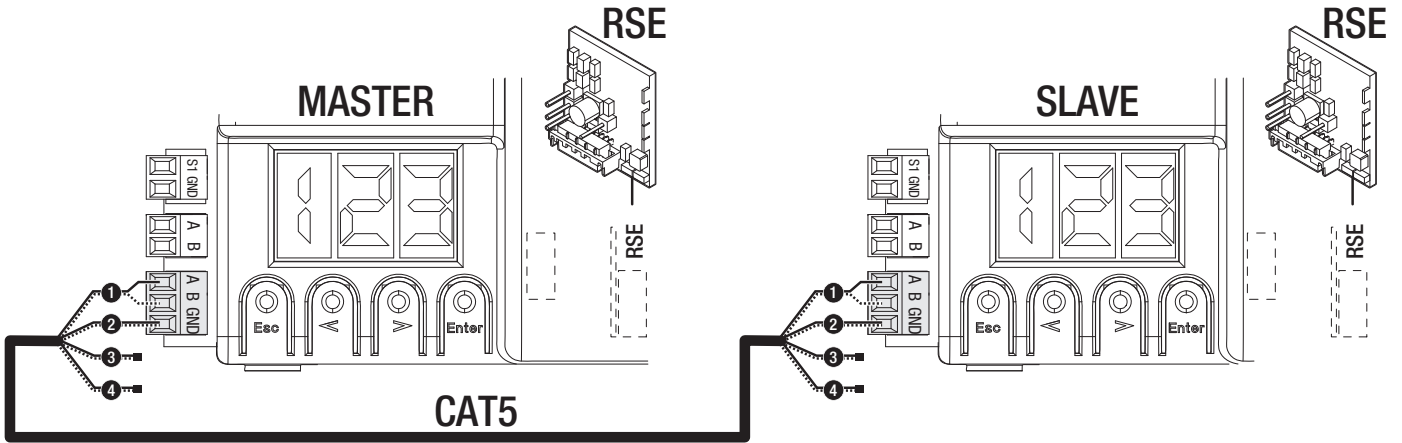

### Programming

 All programming operations described below must be performed only on the control board set as the MASTER.

Start programming with the functions indicated below.

F49 RSE

F54 Opening direction

F52 Transferring MASTER-SLAVE parameters

### Saving users

 All save user operations must be performed only on the control board set as the MASTER.

### Operating modes

① PARTIAL OPENING command

② STEP-BY-STEP command

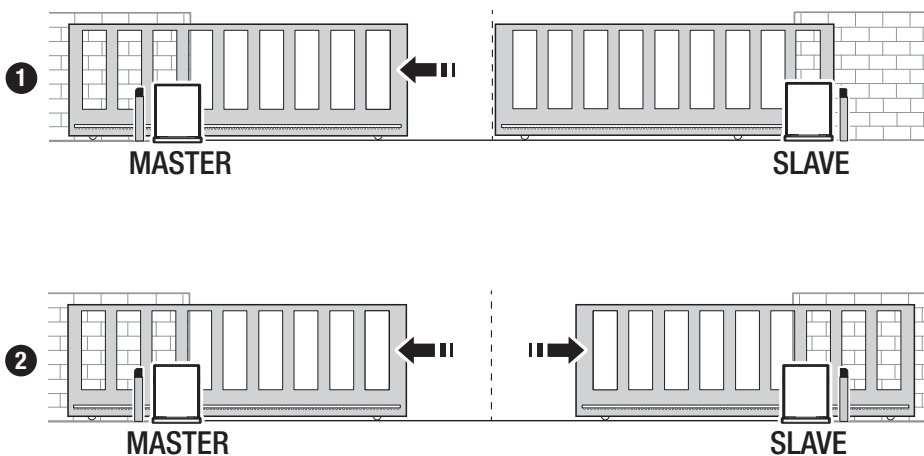

MCBF				
Models	BXV04	BXV06	BXV08	BXV10
14 m - 400 kg	150000	-	-	-
18 m - 600 kg	-	150000	-	-
20 m - 800 kg	-	-	150000	-
20 m - 1000 kg	-	-	-	150000
Installation in windy area	-15%	-15%	-15%	-15%

 The percentages indicate how much the number of cycles should be reduced in relation to the type and number of accessories installed.

 Before carrying out any cleaning or maintenance, or replacing any parts, disconnect the device from the power supply.

 This document informs the installer of the checks that must be carried out during maintenance.

 If the system is not used for long periods of time, e.g. for installations at sites with seasonal closures, disconnect the power supply. When the power supply is reconnected, check the system is working correctly.

 For information on correct installation and adjustments, please see the product installation manual.

 For information on choosing products and accessories, please see our product catalogue.

 Every 10,000 cycles and, in any case, every 6 months of operation, you must perform the maintenance work indicated below.

Perform a general and complete check of the tightness of the nuts and bolts.

Grease all of the moving mechanical parts.

Check the warning and safety devices are working properly.

Check for any wear on the moving mechanical parts and check that they are working properly.

Check the release mechanism is working efficiently by performing a manoeuvre with the leaf free. The gate leaf must not be obstructed.

Check the cables are intact and connected correctly.

Check and clean the slide guide and rack.

Fabbricante / Manufacturer / Hersteller / Fabricant / Fabricante / Fabricante  
/ Wytwórca / Fabrikant

**Came S.p.a.**

Indirizzo / address / adresse / adresse / dirección / endereço / adres / adres  
Via Martiri della Libertà 15 - 31030 Dosson di Casier, Treviso - Italy



DICHIARA CHE LE AUTOMAZIONI PER CANCELLI SCORREVOLI / DECLARES THAT THE DRIVES FOR SLIDING GATES /  
ERKLÄRT DASS DIE AUTOMATISIERUNGEN FÜR SCHIEBETÜRE / DECLARE QUE LES AUTOMATISATIONS POUR  
PORTAILS COULISSANTS / DECLARA QUE LAS AUTOMATIZACIONES PARA PUERTAS CORREDERAS / DECLARA QUE AS  
AUTOMATIZAÇÕES PARA PORTÕES DE CORRER / OŚWADCZA ŻE AUTOMATYKA DO BRAM PRZESUWNYCH /  
VERKLAART DAT DE AUTOMATISERING VOOR SCHUIFHEKKEN

BXV04AGS ; BXV06AGS ; BXV08AGS  
BXV10AGS ; BXV04RGS ; BXV06RGS  
BXV08RGS ; BXV10RGS ; BXV04AGM  
BXV06AGM ; BXV10AGM ; BXV04ALS  
BXV06ALS ; BXV08ALS ; BXV10ALS

SONO CONFORMI ALLE DISPOSIZIONI DELLE SEGUENTI DIRETTIVE / THEY COMPLY WITH THE PROVISIONS OF THE FOLLOWING  
DIRECTIVES / DEN VORGABEN DER FOLGENDEN RICHTLINIEN ENTSPRECHEN / SONT CONFORMES AUX DISPOSITIONS  
DES DIRECTIVES SUIVANTES / CUMPLEN CON LAS DISPOSICIONES DE LAS SIGUIENTES DIRECTIVAS / ESTÃO DE ACORDO  
COM AS DISPOSIÇÕES DAS SEGUINTE DIRECTIVAS / SA ZGODINE Z POSTANOWIENIAMI NASTĘPUJĄCYCH DYREKTYW  
EUROPEJSKICH / VOLDOEN AAN DE VOORSCHRIFTEN VAN DE VOLGENDE RICHTLIJNEN:

- COMPATIBILITA' ELETTROMAGNETICA / ELECTROMAGNETIC COMPATIBILITY / ELEKTROMAGNETISCHE  
VERTRÄGLICHKEIT / COMPATIBILITÉ ÉLECTROMAGNÉTIQUE / COMPATIBILIDAD ELECTROMAGNETICA / COMPATIBILIDADE  
ELETROMAGNETICA / KOMPATYBILNOŚCI ELEKTROMAGNETYCZNEJ / ELEKTROMAGNETISCHE COMPATIBILITEIT : 2014/30/UE.

Riferimento norme armonizzate ed altre norme tecniche / Refer to  
European regulations and other technical regulations / Harmonisierte  
Basissnormen und andere technische Vorgaben / Référence aux normes  
harmonisées et aux autres normes techniques / Referencia normas  
armonizadas y otras normas técnicas / Referência de normas harmonizadas  
e outras normas técnicas / Odnosne normy ujednolicono i inne normy  
techniczne / Geharmoniseerde en andere technische normen waarnaar is  
verwezen

EN 61000-6-2:2005  
EN 61000-6-3:2007+A1:2011  
EN 62233:2008  
EN 60335-1:2012+A11:2014  
EN 60335-2-103:2015

RISPETTANO I REQUISITI ESSENZIALI APPLICATI / MEET THE APPLICABLE ESSENTIAL REQUIREMENTS / DEN WESENTLIJKE  
ANGEWANDTEN ANFORDERUNGEN ENTSPRECHEN / RESPECTENT LES CONDITIONS REQUISES NECESSAIRES APPLIQUÉES  
/ CUMPLEN CON LOS REQUISITOS ESSENCIALES APLICADOS / RESPETAM O REQUISITOS ESSENCIAIS APLICADOS /  
SPEŁNIAJĄ PODSTAWOWE WYMAGANIA WYRUNKI / VOLDOEN AAN DE TOEPASBARE MINIMUM EISEN:

1.1.3; 1.1.5; 1.2.1; 1.2.2; 1.3.2; 1.3.7; 1.3.8.1; 1.4.1; 1.4.2; 1.5.1; 1.5.6; 1.5.8; 1.5.9; 1.5.9; 1.5.13; 1.6.1; 1.6.3; 1.6.4;  
1.7.1; 1.7.2; 1.7.4

PERSONA AUTORIZZATA A COSTITUIRE LA DOCUMENTAZIONE TECNICA PERTINENTE / PERSON AUTHORISED TO COMPILE THE RELEVANT TECHNICAL DOCUMENTATION /  
PERSON DIE BEVOLLMÄCHTIGT IST, DIE RELEVANTEN TECHNISCHEN UNTERLAGEN ZUSAMMENZUSTELLEN / DOCUMENTATION TECHNIQUE SPECIFIQUE D'AUTORISATION  
A CONSTITUIRE DE / PERSONA FACULTADA PARA ELABORAR LA DOCUMENTACIÓN TÉCNICA PERTINENTE / PESSOA AUTORIZADA A CONSTITUIR A DOCUMENTAÇÃO TÉCNICA  
PERTINENTE / OSOBA UPOWAZNIONA DO ZREDAGOWANIA DOKUMENTACJI TECHNICZNEJ / DEGENE DIE GEMÄCHTIGD IS DE RELEVANTE TECHNISCHE DOCUMENTEN  
SAMEN TE STELLEN.

**CAME S.p.a.**

La documentazione tecnica pertinente è stata compilata in conformità all'allegato VIB. / The pertinent technical documentation has been drawn up in compliance with attached  
document VIB. / Die relevante technische Dokumentation wurde entsprechend der Anlage VIB ausgestellt. / La documentation technique spécifique a été remplie conformément à  
l'annexe VIB. / Die documentação técnica pertinente ha sido rellenada en cumplimiento con el anexo VIB. / A documentação técnica pertinente foi preenchida de acordo com o anexo  
VIB. / Odnosne dokumentacja techniczna została zredagowana zgodnie z załącznikiem VIB. / De technische documentatie tarzake is opgesteld in overeenstemming met de bijlage VIB.

CAME S.p.a. si impegna a trasmettere, in risposta a una richiesta adeguatamente motivata delle autorità nazionali, informazioni pertinenti sulle quasi macchine, e / Came S.p.a., following  
a duly motivated request from the national authorities, undertakes to provide information related to the quasi machines, and / Die Firma Came S.p.a. verpflichtet sich auf eine angemessen  
motivierete Anfrage der staatlichen Behörden Informationen über die unvollständigen Maschinen, zu übermitteln, und / Came S.p.a. s'engage à transmettre, en réponse à une demande  
bien fondée de la part des autorités nationales, les renseignements relatifs aux quasi machines / Came S.p.a. se compromete a transmitir, como respuesta a una solicitud adecuadamente  
fundada por parte de las autoridades nacionales, informaciones relacionadas con las cuasimáquinas / Came S.p.a. compromete-se em transmitir, em resposta a uma solicitação motivada  
apropriadamente pelas autoridades nacionais, informações pertinentes às partes que compoñam máquinas / Came S.p.a. zobowiązuje się do udzielenia informacji dotyczących maszyn  
nieukonczonych na odpowiednio umotywowana prośbę, złożoną przez kompetentne organy państwowe / Came S.p.a. verbindt zich ertoe om op met redenen omkleed verzoek van de  
nationale autoriteiten de relevante informatie voor de niet voltooidde machine te verstrekken.

**VIETA / FORBIDS / VERBIETET / INTERDIT / PROHIBE / PROIBE / ZABRANIA SIE / VERBIEDT**

la messa in servizio finché la macchina finale in cui deve essere incorporata non è stata dichiarata conforme, se del caso alla 2006/42/CE. / commissioning of the above mentioned until such  
moment when the final machine into which they must be incorporated, has been declared compliant, if pertinent, to 2006/42/CE / die Inbetriebnahme bevor die „Endmaschine“ in die  
unvollständige Maschine eingebaut wird, als konform erklärt wurde, gegebenenfalls gemäß der Richtlinie 2006/42/EU. / la mise en service tant que la machine finale dans laquelle elle doit  
être incorporée n'a pas été déclarée conforme, le cas échéant, à la norme 2006/42/CE. / la puesta en servicio hasta que la máquina final en la que será incorporada no haya sido declarada  
de conformidad de acuerdo a la 2006/42/CE / a colocação em funcionamento, até que a máquina final, onde devem ser incorporadas, não for declarada em conformidade, se de acordo  
com a 2006/42/CE. / Uruchomienie urządzenia do czasu, kiedy maszyna, do której ma być wbudowany, nie zostanie ozniona jako zgodna z wymogami dyrektywy 2006/42/WE, jest taka  
procedura była konieczna. / deze in werking te stellen zolang de eindmachine waarin de niet voltooidde machine moet worden ingebouwd in overeenstemming is verklaard, indien toepasselijk  
met de richtlijn 2006/42/EG.

Dosson di Casier (TV)  
21 Novembre / November / November /  
November / Noviembre / Novembre /  
Listopad / November 2018

Administratore Delegato / Managing Director /  
General Direktor / Directeur Général / Director General /  
Administrador Delegado / Dyrektor Zarządzający /  
Algemeen Directeur

Andrea Merluzzo

Fascicolo tecnico a supporto / Supporting technical dossier / Unterstützung technische Dossier / soutien dossier technique / apoyo expediente  
técnico / apolar dossier técnico / wspieranie dokumentacji technicznej / ondersteunende technische dossier: 801MS-0150

**Came S.p.a.**

Via Martiri della Libertà, 15 - 31030 Dosson di Casier - Treviso - Italy - Tel. (+39) 0422 4940 - Fax (+39) 0422 4941  
info@came.it - www.came.com

Cap. Soc. 1.610.000,00 € - C.F. e P.I. 03481280265 - VAT ID 03481280265 - REA TV 275359 - Reg Imp. TV 03481280265



**CAME S.P.A.**

Via Martiri della Libertà, 15  
31030 Dosson di Casier  
Treviso - Italy  
Tel. (+39) 0422 4940  
Fax (+39) 0422 4941

**CAME.COM**